



BPC 0007

**ENQUIRY
TWO PART BID**

**भारत हेवी इलेक्ट्रिकल्स लिमिटेड, पिपलानी, भोपाल - ४६२०२२(भारत)
सामग्री प्रबंधन विभाग
BHARAT HEAVY ELECTRICALS LIMITED, PIPLANI, BHOPAL - 462022(INDIA)
MATERIALS MANAGEMENT DIVISION**

TIN NO. 23573600001 | ECC NO. AAACB4146PXM009 | MPCT NO. HEL/05/01/0001/S15/11/79
PHONE: 91-755-2500100 (7 LINE) | FAX: 91-755-2500023 | WWW.BHEL.BHOPAL.COM

ENQUIRY NO E5243157
ENQUIRY DATE 28/03/25
ENQUIRY DUE DATE 25/04/25

SUPP NAME AND ADDRESS	SUPP CODE	REV CD	REV NO	REV DATE	NO OF CATY2	NO OF CATY3	ENQ NO OF ITEMS	INDENT NO
OFFICE COPY		1	0	NA	0	0	5	120440131
	GUARANTEE CERTIFICATE	Y	SUPPLY CONDITION		WITH SUPPLIER'S IDENTIFICATION (PO/DRG/SUPPLIER) ON EACH JOB.			
	TEST CERTIFICATE	Y	TECHNICAL CONDITION		AS PER DRG & QAP NO. QA/MT/BOI/099, REV. 01. DATED . 02.04.2021.			
	INSTRUCTION BOOKLET	N	INSPECTION CONDITION		BY BHEL AT BHEL BHOPAL			
	SAMPLE	N						
GATE PASS	Y							

NOTE: QUOTE PRICE BOTH IN FIGURES & WORDS. IN CASE OF MISMATCH PRICE IN WORDS WILL BE VALID, QUOTATIONS NOT BEARING ENQUIRY NO AND DUE DATE LIABLE TO BE REJECTED.

SL NO	MATERIAL CODE	DESC	UNIT	ITEM QTY	LOT NO	LOT QTY	DEST	DELIVERY DATE
1	BL9084321294	FORGED HEAT TREATED ROUGH MACHINED AND ULTRASONICALLY TESTED RETAINING RING TO DRG. NO. 34028042012#01, REV.04, SIZE-466+1,-0 MM O/D X 425+0,-2 MM I/D X 220 MM HEIGHT, AND SPCN. NO. BP19383. ALTERNATIVELY BP19381 OR X4 CRNIMNMO N 19165 IS ALSO ACCEPTABLE.	NO	8.000	1	8.000	204	31/08/25
2	BP9504323910	FORGED HEAT TREATED ROUGH MACHINED AND ULTRASONICALLY TESTED RETAINING RING TO DRG. NO. 34028042016#01, REV. 04, SIZE-490+1,-0 MM O/D X 450+0,-2 MM I/D X 230 MM HEIGHT, AND SPCN. NO. BP19383. ALTERNATIVELY, BP19381 OR X4 CRNIMNMO N19165 IS ALSO ACCEPTABLE.	NO	11.000	1	11.000	204	31/08/25
3	BP9504323928	FORGED HEAT TREATED ROUGH MACHINED AND ULTRASONICALLY TESTED RETAINING RING TO DRG. NO. 34028042020#01, REV. 04, SIZE-424+1,-0 MM O/D X 388+0,-2 MM I/D X190 MM HEIGHT, AND SPCN. NO. BP19383. ALTERNATIVELY, BP19381 OR X4 CRNIMNMO N19165 IS ALSO ACCEPTABLE.	NO	4.000	1	4.000	204	31/08/25
4	BP9504323936	FORGED HEAT TREATED ROUGH MACHINED AND ULTRASONICALLY TESTED RETAINING RING TO DRG. NO. 34028042033#01, REV. 03, SIZE-540+1,-0 MM O/D X 504+0,-2 MM I/D X140 MM HEIGHT, AND SPCN. NO. BP19383. ALTERNATIVELY, BP19383 OR X4 CRNIMNMO N19165 IS ALSO ACCEPTABLE.	NO	4.000	1	4.000	204	31/08/25
5	BP9504323944	FORGED HEAT TREATED ROUGH MACHINED AND ULTRASONICALLY TESTED RETAINING RING TO DRG. NO. 44028042035#01, REV. 08, SIZE-590+0,-2 MM O/D X 545+0,-2 MM I/D X 200 MM HEIGHT, AND SPCN. NO.	NO	2.000	1	2.000	204	31/08/25

NOTE:BHEL,BHOPAL'S Standard Terms & Conditions BP4255/MM5533 rev02 for imports and BP4255/MM5527 rev03 for indigeneous procurements form a part of this Enquiry.Bidders may obtain from us copies of these terms and conditions if not already available.

SPECIAL REMARKS	<p>NAME : SHRI SAURABH KUMAR SINHA DESG : MANAGER</p> <p align="center">SIGN & SEAL</p>
------------------------	--

ENQUIRY



BPC 0007

**ENQUIRY
TWO PART BID**

**भारत हेवी इलेक्ट्रिकल्स लिमिटेड, पिपलानी, भोपाल - ४६२०२२(भारत)
सामग्री प्रबंधन विभाग
BHARAT HEAVY ELECTRICALS LIMITED, PIPLANI, BHOPAL – 462022(INDIA)
MATERIALS MANAGEMENT DIVISION**

TIN NO. 23573600001 | ECC NO. AAACB4146PXM009 | MPCT NO. HEL/05/01/0001/S15/11/79
PHONE: 91-755-2500100 (7 LINE) | FAX: 91-755-2500023 | WWW.BHELBHOPAL.COM

ENQUIRY NO E5243157
ENQUIRY DATE 28/03/25
ENQUIRY DUE DATE 25/04/25

BP19383. ALTERNATIVELY, BP19381 OR X4 CRNIMMO N19165 IS ALSO ACCEPTABLE.

REMARK (1) OFFERS TO BE SUBMITTED IN TWO PART BID SYSTEM. TECHNO-COMMERCIAL BID & PRICE BID IN SEPARATE ENVELOPES. (2) REFER ANNEXURE BP 200102B:- GENERAL TERMS AND CONDITIONS OF ENQUIRY AS ATTACHED. (3) ALL GST PROVISIONS AS IMPLEMENTED BY GOVT. OF INDIA W.E.F. 01/07/2017 WILL BE APPLICABLE. (4) EARLY DELIVERY IS ACCEPTABLE. (5) QAP APPLICABLE AS PER QAP NO. QA/MT/BOI/099, REV. 01. DATED. 02.04.2021. (6) OVERSEAS VENDORS TO QUOTE ON CIF NHAVA SEVA BASIS. MODE OF TRANSPORT WILL BE SEA (7) RA NOT TO BE DONE. (8) PLEASE SUBMIT TECHNO COMMERCIAL SHEET ANNEXURE-A ALONG WITH OFFER.

DRAWING Y **PURCH SPEC** Y **CATALOUGE** N **PLAN** Y **TWO PART BID** Y

S.NO	INDENT NO	ITEM NO	CATEGORY	ENQUIRY QTY.
1	120440131	1	193300	8.000
2	120440131	2	193300	11.000
3	120440131	3	193300	4.000
4	120440131	4	193300	4.000
5	120440131	5	193300	2.000

NOTE: BHEL, BHOPAL'S Standard Terms & Conditions BP4255/MM5533 rev02 for imports and BP4255/MM5527 rev03 for indigeneous procurements form a part of this Enquiry. Bidders may obtain from us copies of these terms and conditions if not already available.

SPECIAL REMARKS

NAME : SHRI SAURABH KUMAR SINHA
DESG : MANAGER

SIGN & SEAL

**E
N
Q
U
I
R
Y**

**Minimum Technical Qualifications Required for supplying Retaining Ring Forging Grade
Grx4Cr Ni Mn Mo N19138 as per BHEL spec BP19383**

Ref no: AME-IMM/MTQ/RETRING/02

Rev.01/ 30.03.23

Date: 08-12-20

Following are the mandatory requirements. Offers of vendors not meeting these requirements will not be considered.

For foreign vendors already a part of BHEL PMD AEM 01 It.60, please see note 1.

S.N	Description of pre-qualification requirement	Supporting Documents required	Complied (Yes / No)																											
1.	Vendor must have manufactured and supplied at least 3 retaining ring forgings in material grade X4Cr Ni Mn MoN19138 by hot forging + heat treatment process. Out of these retaining ring forging, at least one retaining of dimension Outer diameter : ≥ 400 mm, Inner Diameter: ≥ 350 mm and Height: ≥ 140 mm must have been manufactured and supplied by vendor..	<p>In support of above, the vendor has to furnish details of 3 retaining ring supplies in the following format:</p> <table border="1"> <thead> <tr> <th rowspan="2">Retaining ring</th> <th rowspan="2">Steel Grade: X4Cr Ni Mn MoN19138</th> <th colspan="3">Dimension (in mm)</th> <th rowspan="2">Name of Customer/ Year of supply</th> </tr> <tr> <th>OD</th> <th>ID</th> <th>HT</th> </tr> </thead> <tbody> <tr> <td> </td> <td> </td> <td> </td> <td> </td> <td> </td> <td> </td> </tr> <tr> <td> </td> <td> </td> <td> </td> <td> </td> <td> </td> <td> </td> </tr> <tr> <td> </td> <td> </td> <td> </td> <td> </td> <td> </td> <td> </td> </tr> </tbody> </table> <p>This should be accompanied by Self-declaration (seal signed by authorized signatory on Company's letter head) giving purchase order reference, purchase order date, customer name, quantity supplied and supply date.</p> <p>Test certificate of retaining ring for all the three cases must be submitted with offer.</p>	Retaining ring	Steel Grade: X4Cr Ni Mn MoN19138	Dimension (in mm)			Name of Customer/ Year of supply	OD	ID	HT																			
Retaining ring	Steel Grade: X4Cr Ni Mn MoN19138	Dimension (in mm)			Name of Customer/ Year of supply																									
		OD	ID	HT																										
2.	<p>a. Vendor must have in-house forging/ring rolling, heat treatment and cold expansion facility to manufacture retaining ring forging of material grade X4Cr Ni Mn MoN19138 of drawing dimension. Retaining ring forging has to be manufactured by forging plus cold expansion process. #</p> <p># Any other process of manufacturing is not acceptable. Outsourcing of any of the above process is not acceptable.</p>	<p>Details of in-house manufacturing facilities are to be submitted with offer. Supplier to give Self declaration (seal signed by authorized signatory on Company's letter head) mentioning list of relevant manufacturing facilities owned by the manufacturer.</p>																												
	<p>b. Electro slag re-melted steel shall be used.</p>	<p>Supplier to provide Self declaration (seal signed by authorized signatory on Company's letter head) containing details of in-house melting including Electro Slag Re-melting facility. At least one mill test certificate of material grade X4Cr Ni Mn MoN19138 manufactured in house to be submitted.</p> <p>In case in-house steel melting facility not available, vendor to provide details of steel supplier with their manufacturing facility and experience for material grade X4Cr Ni Mn MoN19138.</p>																												

Mr. Manan
30.03.23

3.	<p>a) The Manufacturer, preferably should have in-house testing facilities to conduct tests as per QAP Plan QA/MT/BOI/099. and as per enquiry.</p> <p>b) If any facility of particular testing is not available in-house then Manufacturer to Outsource labs/firms for testing.</p>	<p>a) Self declaration (seal signed by authorized signatory on Company's letter head) giving details of in-house testing facilities. Test certificates shall cover chemical composition, mechanical properties, dimensional report, non-destructive test report etc. Testing shall be witnessed by BHEL as per QA/MT/BOI/099.</p> <p>b) In case of outsourcing of testing, vendor to agree to test in government/international accreditation agency approved labs.</p>	
4.	<p>Vendor to confirm supply shall be as per BHEL enquiry drawing and specification. Vendor to sign each page of BHEL specification, drawing and QA plan for compliance and submit with offer.</p>		

Note 1: Vendors already a part of BHEL PMD AEM 01 Item No 60, need to provide PO no of at least 02 POs already executed by them in past 5 years of retaining ring of same spec & dimensional requirements in sl no 1. This along with confirmation of acceptance to BHEL enquiry technical requirements establishes the technical suitability of the PMD vendors. Since they are already a part of BHEL PMD, it is evident they are capable of executing and are supplying the retaining rings.

M.K. Maravi
20/03/23
(M K Maravi)
AGM /AME, SSM & ISE

Anand
30/03/23
(Anand Kumar Modi)
Manager /AME

Enquiry No. E5243157 dtd 28-03-2025 due dtd 25-04-2025

DATE :28-03-2025

IMPORTANT: [i] Suppliers to ensure submission of completely filled & duly signed/stamped "Annexure- A" along-with the Offer.

[ii] In case if NOT submitted along-with the offer as required above, all points of "Annexure- A" will be considered to be accepted in totality by the Vendor.

Sl.	IMPORTANT INSTRUCTIONS FOR TENDERER	YES / DEVIATION
1	The offer shall be submitted in two part bid (Part – I & Part –II) viz .Part I – Technical & Commercial Offer & Part II – Price Offer Only. Both Part – I and Part – II should reach in a box kept in our Tender Room before 11 : 00 a.m. on due date in two separate sealed envelopes clearly marked with "Enquiry No. Dated & Due Date : Part – I Technical and Commercial Bid" on 1st envelop and "Enquiry No Dated & Due Date Part – II "Price Bid" to be marked on 2nd envelop. Both envelopes should be sealed in the 3rd envelope. The Enquiry No. Dated and Due Date are to be mentioned on this envelope also. Only part – I will be opened on the same day (i.e. tender opening day) after 2:00 pm. After scrutiny of Part –I, the price bid viz, Part – II will be scrutinized only for those offers which are meeting all our technical and commercial requirements. For scrutinizing price bid which will be opened on a particular date, which will be intimated in advance to all such vendors whose offers are found technically and commercially acceptable. BHEL prefers to get quotations in sealed envelope, however in case of emergency, quotation may be send at email mttender.bpl@bhel.in .	
2	<p>Commercial Terms -</p> <p>Payment Terms : For indigenous supply: 100% payment in 90 days / (45 days for MSE including NSIC/ Udyam registered suppliers as per relevant act in force) after receipt & acceptance of material at BHEL.</p> <p>Whether covered under MSMED (If, yes, a copy of UDYAM certificate is required to be submitted.)</p> <p>Any deviation from the above payment terms, if accepted (by BHEL), shall be loaded @ SBI base rate + 6% for the purpose of bid evaluation. Note : Trading Enterprises & Agent / Dealer shall not be considered under the benefits of MSE in line with guideline issued by ministry of MSE vide office memorandum dt. 09.02.2017.</p> <p>For Foreign supply: 100% against irrevocable, unconfirmed LC, payable within 90 days of the Bill of Lading (B/L) date or Payment terms of CAD payable on 90th day of B/L / AWB. In case of any deviation in payment terms, the bids shall be evaluated with loading of State bank of India Base rate plus 6%, for the credit period short of 90 days.</p> <p>The LC shall be established 2 months prior to shipment date, valid for period of 90 days, unless agreed otherwise.</p>	
3	<p>Penalty Clause: Penalty shall be 0.5% of the total order value per week of delay or part thereof, subject to a maximum of 10% of the total order value</p> <p>[Note: In case of non-acceptance of penalty clause, loading shall be to the extent to which it is not agreed to by the bidder at offered value subject to maximum of 10% of the total order value] for comparison purpose]</p>	
4	<p>Delivery Terms (For indigenous supply) : FOR BHEL Bhopal</p> <p>Delivery Terms (For Foreign Supply): The terms of delivery shall be CIF Nhava Sheva BASIS. Mode of Transport will be by SEA.</p>	
5	Quoted Currency:	
6	Delivery Schedule [indicate in weeks]	
7	Validity of offer [90 days from tender opening date]	
8	HSN/SAC code/GSTIN NO. [Specify clearly HSN/SAC code applicable for quoted item with note that same will be part of P.O.]	
9	CGST_SGST / IGST (Please mention the GST type & percentage (%) of Tax)	
10	The bidder / supplier / contractor will, when presenting his bid, declare whether other family firms or sister concern affiliates / subsidiary firms are participating in the same tender, so as to eliminate the possibility of cartel formation. Format for declaration attached. Please submit the declaration format (Annexure IX) duly filled , signed & sealed, along-with quotation.	
11	This Enquiry is open tender enquiry. Vendor who qualify the MTQ criteria, will be qualified for price bid.	
12	For foreign bidders: Submit the completely filled, signed & sealed PEBC certificate (Annexure I & II) along with techno- commercial offer	
13	A copy of valid authorization certificate from OEM or agency agreement between OEM & agent/dealer (if applicable) to be submitted along-with Part1 - Techno-commercial offer.	
14	In case duty concession benefits are available as per Free trade Agreement between India and the exporting country, supplier has to furnish Certificate of origin (COO) of goods issued by designated authority of the exporting country. COO shall be as per prescribed format in FTA containing details of goods covered and originating criterion fulfilled. Additionally information as per Customs (Administration of Rules of Origin under Trade Agreements) Rules, 2020 (CAROTAR, 2020) may also be sought from supplier at the time of import.	
15	In addition to above, BHEL Bhopal's General terms & conditions of Enquiry BP200102B is the part of tender. Bidder may obtain from us these terms & conditions. Same can be downloaded/seen from https://bpl.bhel.com/mm/	
16	Price : Firm Price	
17	Contact person & details (Email & Telephone)	

AUTHORISED SIGN. & SEAL OF SUPPLIER

(SAURABH KUMAR SINHA)
MANAGER (MEX)



MM 5533

Rev-02

The BHEL Purchases Order subject to the following terms & conditions unless otherwise specified and directed.

1. DOCUMENTATION :**1.1 NON-NEGOTIABLE SET :**

Comprising following :

- (i) Copy of non negotiable Bill of lading / AWB or HAWB with a mention of AWB No.
- (ii) **2 copies of Signed Commercial Invoice**
- (iii) 2 copies of advice Note/detailed packing list in English covering each item and quantity
- (iv) Certificate of Origin
- (v) Inspection/Material Certificate
- (vi) **Catalogue/drg.** for components (including casting & forging) and for finished Goods

OR

Composition certificate for ferrous/non-ferrous metals/insulating & other raw material, casting & forging and other metallic components.

1.1.1 DOCUMENTATION CLAUSE :

*Advance set of documents are to be forwarded to the following within three days of obtaining Bill of Lading/AWB through any international courier service so as to reach us within 10 days from the date of despatch of material. Failure to do so will make the supplier responsible for making good any loss. Please note that the insurance by BHEL does not absolve the supplier from the responsibility of defective/bad packing, short/wrong supply. Details like BL/AWB with date PO No. and value should be furnished by TLX/FAX/E-MAIL to the concerned Purchase officer of BHEL and to our underwriters.

- | | |
|---|--|
| (i) Sr. Manager (M.S.) ROD,
Bharat Heavy Electricals Ltd.
World Trader Centre, Centre 1
14th/15th Floor Cuffe Parade, COLABA
Mumbai 400 005, INDIA Tel: 2180740
FAX : 0091-22-2187850 | (ii) Branch Manager,
M/s. National Insurance Co. Ltd.
First Floor, B-8, Indrapuri,
Bhopal (INDIA) Pin : 462021
Telex : 0705-336-NICL-IN,
CABLE : NIC DIV.-BHOPAL |
| (iii) Dy. General Manager (CRX)
BHEL, BHOPAL (INDIA) PIN-462022
Telex : 0705-7264, 7265
FAX : 0755-201823, 500946 | (iv) Dy. General Manager (MM) Administrative
Building, BHEL, BHOPAL (INDIA)
PIN : 462022
TELEX : 0705-7264, 7265
FAX : 0755-500023
(Two sets) |

1.1.2 Fax/E-Mail confirmation indicating full details of shipment i.e., P.O.No., Vessel Name/Flight No. BL/AWB details, Material, Quantity and consignment value to be sent to other agencies as well at point 1.1.1. above, immediately after shipment/air freight.

1.2 NEGOTIABLE SET :

(i) Supplier should additionally forward documents mentioned at point 1.1 (ii to vi) alongwith original Bill to Lading through any international courier service/registered airmail or AWB by captain's mail within three days of obtaining the same, directly to the following :

- | | |
|--|---|
| (i) Sr. Manager (MS)
Regional Operation Division BHEL,
14th/15th Floors Centre 1
World Trader Centre, Cuffe Parade,
Colaba, Mumbai : 400 005 INDIA
Fax : 0051-22-2187850 | (ii) Manager (FIN) FP
Administrative Bldg. BHEL
BHOPAL 462022 INDIA
Telex : 0705-7264, 7265
Fax : 0755-540425 & 201544 |
|--|---|
- and confirm forwarding details to Sr. manager (MM) FE, BHEL, Bhopal : 462 022 (INDIA)

1.3 INSTRUCTIONS FOR DOCUMENTS :

- (i) Clean Bill of Lading/Copy of AWB in triplicate to be drawn as below :
Shipper : Govt of India
Consignee : BHEL, BHOPAL
Note : Bank not to be notified as consignee or joint Consignee.
- (ii) B/L to be drawn on FOB basis as and freight to pay unless otherwise specified in P.O.
- (iii) In case of **HAWB** a mention should be made of **AWB No.** always.
- (iv) Signed Invoice should indicate quantity and value of all items supplied. If item is supplied in sets, the quantity and value of pieces making each set should be indicated. For supply of spares (including spares supplied with main equipment) sale value breakup should be indicated item wise. **Split up value is a must** together with consolidated value. Also item being supplied should be linked up with purchase order serial No. "Short shipments, if any, should be indicated clearly with quantity and value in the invoice. At the time of subsequent shipment of short shipped items, reference of original invoice should be indicated."

BHARAT HEAVY ELECTRICALS LIMITED

BHOPAL (INDIA) - 462022

MATERIAL MANAGEMENT DEPARTMENT

GENERAL TERMS & CONDITIONS FOR OVERSEAS PURCHASE ORDER

- (v) In case of **Free supply** : It should be indicated if supply is against short shipment or replacement together with earlier shipment details & forward documents as per 1.1 & 1.2 above, invoice should indicate value of material for customs purpose.
- (iv) Packing list should include package-wise details and each item clearly identified with the respective packing list.
- (vii) Any Demurrage/Wharfage paid at the ports because of delay/discrepancy in the above documents will be to the account of supplier or their representative.
- (viii) For correspondence & documentation, language must be ENGLISH or HINDI.
- (ix) **DRG. & Patterns** : All Drgs. and Patterns supplied/paid for by BHEL will remain BHEL property, and shall be returned to BHEL as and when demanded by BHEL.

2. CASE MARKING :

Following details should be clearly marked on each case :

- (i) Shipper : Govt. of India.
- (ii) Consignee : BHEL (BHOPAL) Via MUMBAI (INDIA)
- (iii) BHELORDERNO. _____
- (iv) Port of Entry : _____
- (v) Port of Destination : _____
- (vi) Gross Weight _____ Kgs.
- (vii) Nett Weight _____ Kgs.
- (viii) Brief Description : _____
- (ix) Dimension in MM : _____
- (x) Supplier : _____

3. PACKING :

Material should be packed suitably in all for normal transport by SEA/Air (as case may be) to India and subsequently by Rail/Road to destination point in India. It should be suitably protected against the effects of tropical salt laden climate. Timber in packing should be free from bark, insects and fungi. Special packing should be provided wherever required in addition to above. Damage to the consignment of account of poor/inferior packing shall be to the account of supplier or their representative.

3.1 INSTRUCTION FOR PACKING :

- (i) A broad red band about 100mm (4") wide all round the case just below top for easy identification of BHEL package at the docks, should be painted.
- (ii) All marking for safety, handling, storage and protection etc. are to be clearly marked on the cases as per international practice.
- (iii) A special care should be taken in packing of hazardous material with all precaution for safety.
- (iv) Proper care should be taken to ensure correct case marking and **packing should be in accordance with the details in Advice Note/Packing list.** Any delay in clearance because of wrong case marking will be to the account of supplier or their representative. Similarly, if for any reason whatsoever discrepancies are noticed prejudicing our claim with underwriters/carriers with consequential loss will also be to the account of supplier or their representative.

4. MODE OF DESPTACH :

By Sea / Air as repocified in purchase order.

4.1 BY SEA :

Following conditions will apply in case of shipments from different countries.

- (a) **FROM JAPAN** : Shipping arrangements will be made by Secretary, Shipping Co-ordination Committee, Ministry of Shipping & Transport, New Delhi (India) Cable: TRANSHART NEW DELHI. Fax No. 011-3718614, 3352726, Through First Secretary (Commercial) Embassy of India, Tokyo, Japan.
- (b) **FROM USA/Canada/Mexico/South America**, Shipment to be arranged per IPBC conference vessel through M/S OPT OVERSEAS PROJECT TRANSPORT, INC. (A THYSSEN HANIEL LOGISTIC CO.) 46 SELLERS STREET, KEARNY, N.J. 07032. TEL : (201) 998-7771, Tlx : 673-3586, fax : (201) 998-7833.
- (c) **FORM OTHER THAN USA/CANADA/MEXICO/SOUTH AMERICA & JAPAN** : Shipment to be arranged per IPBC vessel through M/s. Schenker & International, Deutschland GmbH, Beiden Muhren 520457, Hemburg Germany, Fax : 0049-4036135509, their agent in UK are M/s. Schenker Ltd., Royal London House, 13 Finsbury Square, London ES2 OR obtain a certificate from them to the effect that

shipment has been arranged in accordance with instructions of the Ministry of Shipping & Transport, NEW DELHI.)

4.1.1 INSTRUCTIONS FOR DESPATCH :

- (i) Despatch per **Post Parcel is strictly prohibited.**
- (ii) Four weeks' notice to be given to shipping Agents about readiness of cargo for finalising the shipping arrangements. Bank not to be notified as-Consignee or Joint Consignee.
- (iii) Material to be shipped free on board (FOB). Inland freight, packing forwarding etc. to be borne by Supplier other than USA Suppliers who will ship the material on FAS basis.
- (iv) Material will be shipped as break bulk FCL cargo. Specific advice of BHEL, Bhopal shall be necessary for shipping on FCL cargo basis.

4.2 BY AIR :

Material to be airfreighted through our authorised agents/air consolidators as indicated in the Purchase Order/Letter of Credit. In countries where no authorised agent/consolidators exists, supplier himself will arrange shipment through AIR INDIA flight. Refer Documentation Clause for other details.

5. INSURANCE :

Material insurance will be arranged by us at our cost against open Marine Cover obtained from M/s. National Insurance Co. Ltd., Bhopal (India) and advance set of documents should be airmailed directly to them (See Clause 1.1.1)

6. GUARANTEE & TEST CERTIFICATE :

Manufacturer's works test/inspection certificates shall be furnished alongwith the guarantee that material conforms strictly to the specification for general & special conditions as laid down in the purchase order.

7. PENALTY :

Failure to despatch in time as per the terms of delivery mentioned in our order would be liable for supplier, unconditional penalty of 1/2% (half percent) of the price of the goods offered in arrears per week at the discretion of BHEL subject to a maximum of 10% value of the order.

8. DEFICIENCIES & DEFECTIVE GOODS :

Should any deficiency or defect be noticed in the goods same shall be replaced by the supplier without any extra charge under NO CHARGE INVOICE. Any complaint in regard to the material will be notified to the supplier who will replace same promptly. **The rejected material will have to be accepted back by the supplier who will bear its return freight also & the supplier will reimburse to BHEL the customs duty paid" on defective supply and/or unnotified short shipments."**

9. PAYMENT :

Generally through Irrevocable letter of credit as per detailed terms and conditions mentioned therein to be established by BHEL.

10. AGENCY COMMISSION :

Agency Commission, if any, will be paid out of the FOB value after receipt and acceptance of material on inspection, in Indian Rupees on submission of invoice. Exchange rate considered for calculation will be the rate prevailing on the tender opening date or the letter of intent date or date of purchase order, whichever is the lowest.

11. LAWS :

The contract shall be governed by the laws of India

12. ARBITRATION :

All cases of dispute arising out of or relating to this purchase order shall be referred to the sole arbitration of the Executive Director/General Manager/Incharge, General Manager of BHEL, Bhopal or any other person (including an employee of BHEL, even though he had to deal with the matters relating to this Purchase order in any Manner) nominated by the said Executive Director/General Manager (I)/General Manager to act as sole Arbitrator. The arbitration shall be under the Indian arbitration act, 1940 and rules made there under. The arbitrator may from time to time with consent of parties enlarge the time for making and publishing the award. Seat of arbitration shall be Bhopal.

13. JURISDICTION :

All suits or any matters arising out of this purchase order shall lie in Bhopal Courts only.

14.

In line with factories Act, section 41-B and Environment Act schedule 9, Rule 17, and as per the requirement of ISO-14001, please submit the material safety Data sheet (MSDS) of hazardous chemicals being imported, This is required to be kept ready by us for producing as and when asked for by regulating inspecting Government Authorities.

Company Letter head

Date: {insert date}

To,
Bharat Heavy Electricals Limited
Piplani
Bhopal-462023
Madhya Pradesh
India

I/We hereby certify (for the period from* _____ to _____) that,

1. {Name of company} (Vendor Code with BHEL) is a company incorporated on {insert date}{insert date} under the {Law of the Country}
2. It is a tax resident as per the Tax Laws of {country}.
3. The Company does not have and is not likely to have a permanent establishment in India as defined in Article 5 of the Agreement for Avoidance of Double Taxation between India and _____ ("the tax treaty" for short).
4. In this regard, it is further confirmed that:
 - the Company does not have or is not likely to have a fixed place of business in India through which its business is wholly or partly conducted as stipulated in Article 5 of the tax treaty
 - the Company does not have or is not likely to have any dependent agent in India as stipulated in Article 5 of the tax treaty
5. The company does not have any business connection in India as per Sec 9(1) of the Indian Income Tax Act 1961 through which business is carried on in India.

I hereby declare that the above information is correct and complete to the best of my knowledge and belief. Further I undertake to promptly inform the Company (i.e. BHEL) in writing should there be any change in the facts given above.

I/We, my/our legal heirs, executors and administrators hereby indemnify and keep indemnified the Company (i.e. BHEL) for any loss (including but not limited to tax, interest and penalty) suffered by as a result of the Company (i.e. BHEL) relying on this declaration and/or my delay/default in confirming the change, if any, in the facts mentioned above. This obligation shall be in force at all times.

This certificate is being issued to the Customer / Client / Payee to enable them to decide upon the With Holding Tax applicable on transaction with our company.

If there is any change in the above facts the same would be intimated to you.

For& On behalf of

{Insert name of the company}

Authorized Signatory with Seal

*The period can be decided by the issuer & no fresh certificate will be asked for releasing payment within this period.

Company Letter head

Date: {insert date}

To,
 Bharat Heavy Electricals Limited
 Piplani
 Bhopal-462023
 Madhya Pradesh
 India

I/We hereby certify (for the period from *_____ to _____) that,

1. {Name of company} (Vendor Code with BHEL) is a company incorporated on {insert date}{insert date} under the {Law of the Country}
2. It is a tax resident as per the Tax Laws of {country}.
3. The Company has its permanent establishment in India as defined in Article 5 of the Agreement for Avoidance of Double Taxation between India and _____ ("the tax treaty" for short).
And/or
4. the Company has a fixed place of business in India through which its business is wholly or partly conducted as stipulated in Article 5 of the tax treaty
And/or
5. the Company has agent(not of independent status) in India as stipulated in Article 5 of the tax treaty
And/or
6. The company has business connection in India as per Sec 9(1) of the Indian Income Tax Act 1961 through which its business is carried on in India.

But as far as our business dealing with your organization is concerned we are not using this permanent establishment and business connections and we are dealing directly from our office situated in _____.

I hereby declare that the above information is correct and complete to the best of my knowledge and belief. Further I undertake to promptly inform the Company (i.e. BHEL) in writing should there be any change in the facts given above.

I/We, my/our legal heirs, executors and administrators hereby indemnify and keep indemnified the Company (i.e. BHEL) for any loss (including but not limited to tax, interest and penalty) suffered by as a result of the Company (i.e. BHEL) relying on this declaration and/or my delay/default in confirming the change, if any, in the facts mentioned above. This obligation shall be in force at all times.

This certificate is being issued to the Customer / Client / Payee to enable them to decide upon the With Holding Tax applicable on transaction with our company.

If there is any change in the above facts the same would be intimated to you.

For & On behalf of

{Insert name of the company}

Authorized Signatory with Seal

*The period can be decided by the issuer & no fresh certificate will be asked for releasing payment within this period.



BP 200102B

HEAVY ELECTRICALS PLANT, BHOPAL

GENERAL TERMS AND CONDITIONS OF ENQUIRY

Sl.No.	Description
1	General:
1.1	<p>These General terms & conditions (GTC) shall apply to all enquiries, notice inviting tenders, request for quotations concerning the supply of goods and / or rendering of services to Bharat Heavy Electricals Ltd., Bhopal (hereinafter referred to as BHEL or the Purchaser) or its Projects / Customers. Special / supplementary enquiry conditions, if any, will override the conditions in this annexure. In case of placement of order these conditions will become part of Purchase Order (P.O) until unless the deviations are specifically agreed by BHEL.</p> <p>In case of any inconsistency, conflicts or contradiction among any of the contract documents, the interpretations will be based on the following order of precedence:</p> <ol style="list-style-type: none">Amendments to Purchase Order/ Framework AgreementPurchase Order/ Framework AgreementLetter of intent (LOI)/ Letter of Award (LOA)Minutes of meeting or Clarifications agreed between Buyer and Seller as regards to the tender or the bidding conditionsCorrigenda to NIT, with those of later date having precedence over those of earlier dateOriginal NIT and annexures except documents listed in point no (vii) to (ix) belowTechnical specifications including their annexuresSpecial Terms and condition of Enquiry (STC)General Terms of Enquiry (GTC)
2	General Instructions - Common for Indigenous & Foreign enquiries
2.1	Through eProcurement <ol style="list-style-type: none">Interested bidders / suppliers shall submit their offer through e-procurement mode at https://eprocurebhel.co.in/nicgep/appOffers in any other mode will not be accepted.Procedure for submission of tender is available in the "Bidder Manual Kit" at e-tender portal https://eprocurebhel.co.in/.In case of any difficulty faced while registering on BHEL's e-Procurement portal developed by NIC, queries may be addressed to 0120-4001002, 0120-4001005 and 0120-4493395 email: support- eproc@nic.in. These details are also available on Contact Us page of the portal.Before uploading scanned documents if any, the bidders shall sign on all the statements, documents, certificates etc uploaded by him, owning responsibility for their correctness / authenticity.Disclaimer clause: Neither the Organization (Bharat Heavy Electricals Ltd.) nor the service provider is responsible for any failure of submission of bids due to failure of internet or other connectivity problems or reasons thereof.
2.2	Through tender room (Conventional tender)
2.2.1	<p>Sealed bids are invited for scope of Supply / Services as detailed in the enquiry.</p> <p>Bid should be free from correction, overwriting, using of corrective fluid etc. Any interlineation, cutting, overwriting shall be valid only if they are attested under full signature(s) of persons signing the bid else shall be liable for rejection.</p> <p>All overwriting/ cutting etc. will be numbered by bid opening officials and announced during bid opening.</p> <p>The bid should be submitted in English or Hindi language. Relevant enclosures, supporting documents, catalogue, samples, if any, as required as per Notice Inviting Tender (NIT) conditions shall be sent along with technical offer. Rate should be quoted in the units asked for in the enquiry.</p>
2.2.2	<p>Bids shall be submitted in a Sealed cover with Enquiry No., Due date and Bidder's name indicated on the cover.</p> <p>In case of Two Part Bid, technical bid containing technical offer, this GTC duly filled-in & signed; and un-priced copy of the Price Bid should be kept in one envelope. Price Bid containing only the price (as called for in the price format where required) should be kept in a separate envelope. Both envelopes indicating Part —I or Part-II as the case may be to be put in a bigger envelope, which should be addressed to in charge, Tender Room, Bharat Heavy Electricals Ltd. 2nd Floor, Jawahar Bhavan, Piplani, Bhopal 462022. Enquiry No., due date and bidder's name must be mentioned on all envelopes. Offer must reach tender room of BHEL Bhopal latest by 11.00 am IST on the enquiry due date.</p> <p>Bids submitted as single part bid against two – part bid, shall be rejected unless the offer is techno-commercially acceptable without seeking any clarification.</p>
2.2.3	<p>Offer received after 11.00 AM IST of the due date will be termed as "Late" and shall not be considered. However, late offer received against single tender enquiry may be considered.</p>
2.2.4	<p>Bidder can also submit offer through email id mmtender.bpl@bhel.in or if called for in the enquiry, at the designated /authorized email address indicated in the enquiry. Such email offers shall be sent only on designated email-id to reach before 11.00 am IST on the tender due date. BHEL will not be responsible for incomplete offers and the ones delivered late through e-mail. Bidder shall have no claim on e-mail offers sent to any other e-mail ID. In case of e-mail offers, the</p>



BP 200102B

HEAVY ELECTRICALS PLANT, BHOPAL

GENERAL TERMS AND CONDITIONS OF ENQUIRY

	mail subject should contain Enquiry Number, Due date and Bidder name. Bidder address including contact details shall be mentioned in the content of the mail. Without these details, the offer is liable for rejection. All techno commercial terms & conditions mutually agreed prior to price bid opening shall prevail and supersede any terms and conditions specified otherwise in price bid.
2.3	Through tender room or EProcurement
2.3.1	Commercial Conditions quoted by the bidder in any place including as stated in bidder's 'General Terms and Conditions' if any, shall not be binding on the Purchaser and the conditions contained in this annexure, including special conditions, if any, for this enquiry shall only prevail.
2.3.2	Rate should be quoted in the units asked for in the enquiry. The rates should be quoted both in figures and words. In case of discrepancy in figures and words, the rates quoted in words shall be considered.
2.3.3	The goods offered shall conform to BHEL specifications and / or National/International standards as mentioned in the Enquiry and the bidder is required to confirm his unconditional acceptance to the same. Bidders, seeking deviations from the specifications and any other conditions, may indicate the same clearly on a separate sheet indicating Sl. No. of the item, with reasons for such deviations. BHEL reserves the right to reject the offer with deviations or load the deviations suitably for evaluation.
2.3.4	Offers shall be submitted directly by bidder or his authorized agent only. Unsolicited offers shall be summarily rejected.
2.3.5	Bid in single part or techno-commercial bid in two-part system (as the case may be) will be opened on the due date. In case of two part bid, price bids of techno-commercially accepted bidder(s) only shall be opened on the assigned date, for which separate intimation will be sent to the accepted bidders.
2.3.6	<p>Whenever specified /called in special /additional /tender specific remakes of tender the Bid Security/ Earnest Money Deposit (EMD)] is to be submitted by bidders along with their bids (except Micro and Small Enterprises (MSEs) or Startups as recognized by Department for Promotion of Industry and Internal Trade (DPIIT)).</p> <p><u>Modes of deposit</u></p> <p>a) The EMD may be accepted only in the following forms:</p> <p>(i) Electronic Fund Transfer credited in BHEL account (before tender opening).</p> <p>(ii) Banker's cheque/ Pay order/ Demand draft, in favour of BHEL (along with offer).</p> <p>(iii) Fixed Deposit Receipt (FDR).</p> <p>(iv) Bank Guarantee from any of the Scheduled Banks.</p> <p>(v) Insurance Surety Bonds.</p> <p>b) In case the EMD is more than Rupees Two lakh and in case of foreign bidders, it may be in the form of a bank guarantee (in equivalent Foreign Exchange amount, in case of foreign bidders) issued/ confirmed from any of the scheduled commercial bank in India in an acceptable form. The EMD shall remain valid for a period of 45 (forty-five) days beyond the final bid validity period.</p> <p><u>Forfeiture of EMD</u></p> <p>(i) A bidder's EMD will be forfeited if the bidder withdraws or amends its/ his tender or impairs or derogates from the tender in any respect within the period of validity of the tender or if the successful bidder fails to furnish the required performance security within the specified period mentioned in the Tender.</p> <p>(ii) EMD by the tenderer to be withheld in case any action on the bidder is envisaged under the provisions of extant "Guidelines on Suspension of business dealings with suppliers/ contractors" and forfeited/ released based on the action as determined under these guidelines.</p> <p><u>Others Instructions</u></p> <p>(i) Bid securities of the unsuccessful bidders should be returned to them at the earliest after expiry of the final bid validity period and latest by the 30th day after the award of the contract. However, in case of two packet or two stage bidding, Bid securities of unsuccessful bidders during first stage i.e. technical evaluation etc. will be returned within 30 days of declaration of result of first stage i.e. technical evaluation etc.</p> <p>(ii) Bid security will be refunded to the successful bidder on conclusion of the order/ receipt of a performance security (if called in the tender).</p> <p>(iii) EMD shall not carry any interest.</p>
2.3.7	<p>1.Any discount / revised offer submitted by a bidder on its own shall be considered, provided it is received on or before the due date and time of offer submission (Part-I). Conditional discounts shall not be considered for evaluation of tenders.</p> <p>2.Unsolicited discounts / revised offers given after Part-I bid opening shall not be accepted. No change in price will be permitted within the validity period of offer.</p> <p>3.In case of changes in scope and / or technical specification and / or commercial terms & conditions, having price implication, techno-commercially acceptable bidders shall be asked by BHEL to submit the impact of such changes on</p>



BP 200102B

HEAVY ELECTRICALS PLANT, BHOPAL

GENERAL TERMS AND CONDITIONS OF ENQUIRY

	their price bids. In case a bidder opts to submit revised price bid instead of impact called for, then latest price bid shall prevail. However in both situations, original price bid will be necessarily opened.
2.3.8	The bidders will submit Integrity Pact, duly signed by its authorized signatory, where called for in the enquiry.
2.3.9	Unregistered suppliers, who are techno-commercially qualified against the open tender, are requested to register with BHEL-Bhopal as permanent supplier by submitting the Supplier Registration Form (SRF) in online supplier registration portal (https://supplier.bhel.in/). Un-registered vendors may be approved by BHEL, if found suitable, on the basis of data furnished by them in Supplier Registration Form (SRF) for Foreign Vendors or Indigenous Vendors (as applicable)
2.3.10	BHEL expects that the bidder responds to the enquiry. Regret letter, with valid reasons for not participating in the tender will be submitted where the bidder is unable to submit offer. Repeated lack of response on the part of bidder may lead to his deletion from BHEL's approved bidder list. Refer guidelines for suspension of Business Dealings with Suppliers/Contractors available on https://www.bhel.com/sites/default/files/suspension_guidelines_abridged.pdf
2.3.11	In case of open tenders (i.e. those published in website) all corrigenda, addenda, amendments, time extensions, clarifications etc. to the tender will be hosted on BHEL website. (https://bhel.com/tenders) and additional in https://eprocurebhel.co.in/nicgep/app for e-procurement tenders. Bidders responding to these tender should regularly visit website(s) to keep themselves updated.
2.3.12	In the course of evaluation, if more than one bidder happens to occupy L-1 status effective L-1 will be decided by soliciting discounts from the respective L-1 bidders in sealed envelope and will be open in tender room. In case more than one bidder happens to occupy the L-1 status even after soliciting discounts, the L-1 bidder shall be decided by a toss/ draw of lots, in presence of the respective L-1 bidders or their representatives. Ranking will be done accordingly. BHEL's decision in such situations shall be final and binding.
2.3.13	The Purchaser can consider awarding tendered quantities among more than one bidder (after acceptance of L1 price by the other bidders) in the manner and proportion disclosed in the tender conditions. Purchaser can also consider awarding of part of the tendered quantity to other than L-1 bidder at L1 counter offered rates, if the quantity offered by the L-1 bidder is less than the quantity tendered for.
2.3.14	The bidder shall submit price bid strictly in the price format, wherever provided for, in the enquiry. Any attempt on the part of the bidder to alter the contents of the price bid format in any manner, which in the opinion of BHEL can vitiate the tendering process, will lead to rejection of the bid, <i>besides BHEL taking appropriate punitive action as deemed fit.</i> Refer Guidelines for suspension of Business Dealings with Suppliers/Contractors available on https://www.bhel.com/sites/default/files/suspension_guidelines_abridged.pdf
2.4	BHEL shall be resorting to Reverse Auction (RA) (Guidelines as available on www.bhel.com). If tender specific conditions call for reverse auction, RA shall be conducted among the techno-commercially qualified bidders. Price bids of all techno-commercially qualified bidders shall be opened and same shall be considered for RA. In case any bidder(s) do(es) not participate in online Reverse Auction, their sealed envelope price bid along with applicable loading, if any, shall be considered for ranking
2.5	BHEL reserves the right to negotiate with L1 vendor or re-float the tender for items. BHEL reserves the right to decrease the tender quantity in case where negotiation is being held.
3	Delivery Terms
3.1	Indigenous Purchase
3.1.1	Goods shall be delivered on 'FOR Destination' basis to the named destination unless otherwise called for in the enquiry.
3.2	Foreign Purchase — Imports
3.2.1	<ol style="list-style-type: none">1. Goods shall be despatched by Sea, unless stated otherwise in the enquiry or purchase order.2. Terms of Delivery for Sea shipment shall be on CFR / CIF basis with 14 days' detention free period preferably at Nhava Sheva (JNPT-INNSA1) for FCL (Full Container Load) Cargo of GP & HC Containers.3. For other cases - Other than GP & HC Containers, LCL Cargo shall be delivered at Nhava Sheva (JNPT- INNSA1) & Break-bulk Cargo at Mumbai (MPT - INBOM1).4. For Air consignments, the terms of delivery shall be FCA at BHEL nominated Airport. In case of CIP, delivery shall be at Mumbai ACC (INBOM4).5. Freight amount shall be indicated separately in the offer in case of CIP/CFR/CIF.6. The number of detention free days and destination charges payable to shipping line must be mentioned in your offer and also on the Bill of Lading.7. Offer received on FOB basis may be considered on an exceptional basis. BHEL will load freight, marine insurance & shipping line port handling charges etc. to work out landed cost at Sea Port.8. Please visit BHEL Bhopal website https://bpl.bhel.com or refer special terms and conditions of tender enquiry for details of named Air ports and Sea ports. Name of the gateway port so chosen by the bidder shall be indicated by the Bidder in his offer.



BP 200102B

HEAVY ELECTRICALS PLANT, BHOPAL

GENERAL TERMS AND CONDITIONS OF ENQUIRY

	<p>9a In case of CIP/CFR/CIF, the shipping line should be ready to move the containers to consignee's nominated CFS (Container Freight Station) yard and Indian agent of shipping line should issue Cargo Arrival Notice (CAN) 7 days in advance.</p> <p>9b In case of CFR contract, bidder to supply the material through a Certified Sea worthy vessel age not more than 15 years.</p> <p>9c The invoices being issued by shipping lines must be in the name of BHEL. Otherwise, BHEL will recover loss of Input Credit on GST from the vendor.</p> <p>9d While booking the shipment, bidder to also finalize destination charges and the same should appear over BL or agreed tariff to be provided to BHEL before arrival of shipment. If cargo is stuffed in container, then the same should be allowed to be moved to CFS of importer's choice without any additional charges.</p> <p>9e Load port charges shall be settled by the supplier and not be passed on to BHEL in any form of destination charges.</p> <p>10. For reasons of delay in receipt of documents from suppliers or due to the same being found to be incomplete, and or faulty, the suppliers shall be responsible to reimburse all penalties, detention and demurrages / wharfages, if any paid by BHEL (for stated reasons).</p>	
3.2.2	<p>1. For delivery of FCL (Full Container Load) cargo, the Bidder shall provide minimum 14 days' detention free period from the date of delivery at Port of Discharge / Place of Delivery (in case of ICD). Wherever the detention free period offered is less than 14 days, the bids shall be loaded for the period short of 14 days' period.</p> <p>2. <u>Port Congestion charges or any additional charges claimed by the shipping line at Port of Discharge / Place of Delivery shall be to the Bidder's account.</u></p>	
4	Bidder's particulars & logistics information (Bidder to give details against each of the provisions)	
4.1	Name of the bidder's executive to deal with this tender / project	
4.2	E-mail address of the contact person	
4.3	Telephone no. of the contact person	
4.4	Name of location from where the goods shall be offered for inspection and dispatch	
5	Additional logistics information for Imports	
5.1	Bid currency	
5.2	Charges applicable at discharge port up to BHEL's CFS (Container Freight Station) to be indicated in your offer and on the B/L	
5.3	Name of Airport in the country of dispatch for FCA delivery terms	
5.4	Estimated number, type & size of containers for delivery of tendered quantity (applicable where the goods are to be sent in FCL)	
5.5	No. of packages with cumulative gross weight and CBM volume (applicable for LCL & Break-bulk shipment)	
5.6	Approx. distance in km. from Bidder's works to Port of Loading	Sea port /Air port
6	Delivery Schedule & Completion date	
6.1	<p>i. Instead of writing specific date against delivery offered, bidder shall commit delivery period in number of days / weeks/ months to suit the delivery period indicated in the enquiry.</p> <p>ii. Commencement of delivery period shall be reckoned from the date of PO / LOI or any other agreed milestone.</p> <p>iii. Bidder shall deliver the goods in the manner and schedule agreed under the Purchase order.</p> <p>iv. Goods shall be delivered within contractual period or any extension thereof, if any, granted by the Purchaser.</p> <p>v. If delivery is linked to approval of documents, time for submission of such documents to be indicated and delivery period to be indicated from approval of documents. This delivery schedule will be considered for processing delivery extension, wherever applicable.</p> <p>vi. BHEL reserves the right to cancel the order if material is not delivered within PO scheduled delivery.</p> <p>vii. Suitable action against defaulting vendor will be taken as per Guidelines for suspension of Business Dealings with Suppliers/Contractors available on https://bhel.com/guidelines-suspension-business-dealings-supplierscontractors</p>	
6.2	In case of foreign supplies, the date of Bill of Lading (B/L) or AWB shall be taken as actual date of delivery where freight until discharge port in India is in Seller's scope like CFR/CIF/CIP delivery terms. For Ex-works/FCA/FOB or any other delivery term where freight is in buyer's scope, date of material readiness /Test certificate/ Warehouse receipt/Freight forwarder receipt may be considered as actual date of delivery (mutually agreed).	



BP 200102B

HEAVY ELECTRICALS PLANT, BHOPAL

GENERAL TERMS AND CONDITIONS OF ENQUIRY

6.3	In case of Indigenous bidders, the date of delivery at named destination in India shall be taken as contractual delivery completion date where delivery terms are FOR destination. In case of 'Ex-works' delivery terms, the date of LR / RR shall be the contractual delivery completion date.
7	Transit Insurance
7.1	Except where delivery terms are agreed on CIF basis for Imports & FOR destination basis for indigenous purchases, transit insurance will be covered by BHEL under its Open Marine Transit Insurance Policy. Bidder shall inform dispatch particulars with value of consignment to the Purchaser within 07 days of dispatch for BHEL to arrange insurance coverage in its policy. Failure on the part of bidder to inform dispatch particulars will make him liable to pay for any transit damages / losses suffered by the Purchaser.
8	Force Majeure
8.1	Notwithstanding anything contained in the contract, neither the Bidder nor the Purchaser shall be held responsible for total or partial non-execution of any of the contractual obligations, should the obligation become unreasonably onerous or impossible due to occurrence of a 'Force Majeure' which directly affects the obligations to be performed by the Purchaser or the Bidder; Such events include war, military operations of any nature, blockages, revolutions, insurrections, riots, civil commotions, insurgency, sabotage, acts of public enemy, fires, explosion, epidemics, quarantine restrictions, floods, earthquake, or acts of God, restrictions by Govt. authorities; over which the Bidder or the Purchaser has no control. The party claiming to be affected by force majeure shall notify the other party in writing without delay, within two weeks on the intervention and on the cessation of such circumstance. Extension of time sought by the Bidder along with supporting evidence and so granted by the Purchaser for the supply/ work affected, if any, shall not be construed as waiver in respect of remaining deliveries. Rescheduling of deliveries on account of force majeure conditions, if so agreed by the Purchaser, will not entail the Bidder to claim any increase in the price on whatsoever account. Notwithstanding above provisions, Purchaser shall reserve the right to cancel the order/ Contract, wholly or partly, in order to meet the overall project schedule and make alternative arrangements. If deemed necessary, Purchaser may takeover partly processed material at a mutually agreed price.
9	Penalty for Late Delivery
9.1.1	Unless covered under Force Majeure conditions aforesaid, Penalty for late delivery shall be 0.5% of the undelivered portion per week of delay or part thereof, subject to a maximum of 10% of the undelivered order value owing to delayed delivery . Total undelivered order value above shall be item wise, lot wise order value of PO . Any deviation from above, which is based on specific requirement/LD clause, shall be specified in particular tender /Special terms and condition(STC) /Additional terms and conditions(ATC) and same shall have overriding effect on anything mentioned in instant GTC. Imposition, recovery or settlement of this penalty shall not adversely affect BHEL's right to performance, compensation and termination of the order.
9.1.2	However, in case of Capital Machine / BOP (Balance of plant) where staggered deliveries may be applicable, the penalty will be levied on total order value. Any deviation based on specific requirement shall be specified separately in the NIT/STC/ATC. In case of Capital items /Balance of plant (BOP) item where services of installation /erecting & commissioning /supervision is desired with supply (Milestone delivery terms) , the LD clause will be separately mentioned in particular tender /Special terms and condition(STC) /Additional terms and conditions(ATC)
9.1.3	In case of any amendment / revision, the penalty shall be linked to the amended / revised PO.
9.1.4	Any loading on penalty clause shall be to the extent to which it is not agreed to by the bidder (at offered value)
9.2	In case the contractually agreed delivery date falls on a holiday in BHEL Bhopal, the next working day shall be taken as contractual delivery date for compliance and applicability of LD / penalty.
9.3	In case of any recovery for delayed performance, the applicable GST shall also be recoverable from bidders.
10	Indian Agents and Agency commission
10.1	BHEL prefers to deal directly with Foreign bidder, wherever required, for procurement of Goods. However if the Foreign Principal desires to avail services of an Indian Agent, then the Principal should ensure compliance to "regulatory guidelines" which will require submission of an agency agreement.
10.2	The CFR / CIF price quoted will be deemed to be inclusive of Indian Agency commission. Agency commission as disclosed by the bidder in his quoted CFR / CIF price will be paid in Indian Rupees on receipt & acceptance of Materials or it's installation at destination, as the case may be. The lower of the 'TT buying rate prevailing on the date of technical bid opening or price bid opening shall be considered for computation of Agency commission.



BP 200102B

HEAVY ELECTRICALS PLANT, BHOPAL

GENERAL TERMS AND CONDITIONS OF ENQUIRY

10.3	In a tender either the Indian Agent on behalf of Principal / OEM or the Principal / OEM itself can bid, but both cannot bid simultaneously for same item / product in the same Tender. In case bids are received from both the Principal / OEM and the agent, bid received from the agent will be ignored.		
10.4	If an agent submits Bid on behalf of the Principal / OEM, the same agent shall not submit bid on behalf of another Principal / OEM in the Tender, for the same Item / Product.		
11	Documentation:		
11.1	Indigenous Purchase		
	<p>Bidder shall arrange to send to the consignee following documents immediately on despatch of the goods. Documents can also be uploaded at Incoming Material Document Management System (IMDMS) available at BHEL Bhopal B-2-B site of BHEL Bhopal internet page at https://bpl.bhel.com/mm/. Online submission of Invoices /e-invoices for payment can also be done in IMDMS system.</p> <ol style="list-style-type: none"> 1) Original Tax invoice in triplicate (Buyer's copy and duplicate for Transporter), 2) Consignee copy of LR & 2 sets each of Packing list, 3) Test certificate, Guarantee / Warranty certificate, 4) O & M manuals (where applicable) 5) In case of labour / mixed basis jobs, material is issued free of cost. Necessary material reconciliation is to be done and Free Issue Material Statement (FIMS) is to be submitted with each bill. 6) Pre-dispatch Inspection report /Third Party Inspection Certificates/MDCC certificate 7) Any other documents as specified in Enquiry /PO /STC/ATC of enquiry /annexure <p>The distribution of such documents will be specified in the Purchase order Terms and Conditions (BP 205315 for indigenous and BP205316 for Imported Purchases))</p>		
11.2	Foreign Purchase — Imports		
	<p>Seller shall send 1 set of following documents, in English, within 7 days of B/L date / 1 day of AWB date by courier to the Purchaser</p> <ol style="list-style-type: none"> 1. Express / Original 'Clean on board' Bill of Lading / AWB. 2. One set of Commercial Invoice, Packing list indicating container-wise Gross weight, Net weight, CBM volume, No. of packages with Dimensions of each package. 3. Original Certificate of Country of Origin (COO) issued by Chamber of Commerce. COO shall be as per requisite format where duty concession is available under Preferential Trade/Comprehensive Economic Partnership/Free Trade agreement. Customs tariff heading (CTH)/ Harmonized System of Nomenclature (HSN) code of material should be mentioned on invoice and COO in all such cases. 4. One set of Original Test Certificates and O&M Manual where called for. 5. Fumigation / Phyto-Sanitary Certificate wherever cargo is packed in wooden packing or packing of plant origin material is used. 6. Supplier should additionally forward 2 sets of original documents mentioned at point nos. 1 to 5 above along with Original Bill of Lading (OBL) or AWB through any international courier service/registered airmail within three (3) days of obtaining the same directly to the following: <table border="1" style="width: 100%; border-collapse: collapse;"> <tr> <td style="width: 50%; padding: 5px;"> AGM (M.S) Regional Operations Division BHEL 14th Floor Centre-1 World Trade Centre, Cuffe Parade Mumbai 400 005 INDIA Email: msseabpl@bhel.in (In case of Sea freight) msair@bhel.in (In case of Air freight) </td> <td style="width: 50%; padding: 5px;"> DGM (FIN- FP) 4th Floor, Administrative Bldg. BHEL Bhopal - 462022 (India) E-mail : fin_fp.bpl@bhel.in </td> </tr> </table> <p style="text-align: center;">And confirm forwarding details to AGM (CMM- FE), BHEL Bhopal at mmfe.bpl@bhel.in</p> <ol style="list-style-type: none"> 7. In case the Seller decides to negotiate all 3 originals of B/L / AWB along with all original documents through negotiating Bank, non-negotiable documents (NNDs) consisting of copy of B/L / AWB & documents mentioned at Sl. no. 11- B2 to B5 will be sent by e-mail to the Purchaser at his e-mail address given in the PO with one copy to be mailed at mmfe.bpl@bhel.in as well as at msseabpl@bhel.in (for Sea shipment) or msair@bhel.in (for Air shipment). Other documents, as required, will be separately indicated in the Purchase Order. Additional expenditure, if any, incurred by the Purchaser by way of detention / demurrage, resulting out of delay attributable to the Seller in providing Negotiable documents, will be recovered from the Seller. <p>In case any discrepancy is raised by the Bankers / BHEL with respect to the documents submitted, vendor to facilitate clearance of goods through Delivery Order.</p> <p>Additionally, following requirements to be taken care of by the bidder during PO execution stage:</p> <ol style="list-style-type: none"> i) IEC (0588138690), GSTIN (23AAACB41461ZN) and email ID (mmfe.bpl@bhel.in) of BHEL Bhopal shall be clearly 	AGM (M.S) Regional Operations Division BHEL 14 th Floor Centre-1 World Trade Centre, Cuffe Parade Mumbai 400 005 INDIA Email: msseabpl@bhel.in (In case of Sea freight) msair@bhel.in (In case of Air freight)	DGM (FIN- FP) 4 th Floor, Administrative Bldg. BHEL Bhopal - 462022 (India) E-mail : fin_fp.bpl@bhel.in
AGM (M.S) Regional Operations Division BHEL 14 th Floor Centre-1 World Trade Centre, Cuffe Parade Mumbai 400 005 INDIA Email: msseabpl@bhel.in (In case of Sea freight) msair@bhel.in (In case of Air freight)	DGM (FIN- FP) 4 th Floor, Administrative Bldg. BHEL Bhopal - 462022 (India) E-mail : fin_fp.bpl@bhel.in		



BP 200102B

HEAVY ELECTRICALS PLANT, BHOPAL

GENERAL TERMS AND CONDITIONS OF ENQUIRY

	<p>mentioned on B/L or AWB.</p> <p>ii) As per Uniform Customs Practice (UCP 600) for documentary credits (L/C), presentation period allowed is maximum 21 days after the date of shipment. However, for geographically closer ports where sea voyage time is less than 3-4 weeks, a shorter presentation period shall be agreed upon.</p> <p>iii) In case of CAD payment terms, Supplier shall send documents to BHEL's bank within 5 days of shipment. One set of original may be sent to any one of ROD, CMM-FE and MM, copy may be marked to the others.</p> <p>iv) For Air shipments through non-CONSOL (i.e., not through BHEL ROD's contract), Delivery Order (DO) should be given to BHEL without insisting for Bank Release Order (BRO). AWB to be drawn with BHEL Bhopal as consignee.</p> <p>v) It must be ensured that original shipping/commercial documents, if not provided to BHEL outside banking channel, should reach BHEL's bank at least 10 days prior to cargo arrival at port.</p> <p>vi) Part shipment and trans-shipment to be avoided to the extent possible especially where it is not possible to split shipping & commercial documents. Part shipment shall be strictly avoided for Airshipments.</p>
11.3	General
	<ol style="list-style-type: none">1. For Hazardous chemicals, the materials safety data sheet (MSDS) is to be submitted.2. All certificates as called must be sent. BHEL may test any goods supplied and their decision is final irrespective of supplier's certificates. If test certificate and guarantee certificate are not received along with the document and stipulated in these specifications, BHEL reserves the right to get the material tested and recover the expenses from the supplier without awaiting supplier's confirmation3. Goods shall be properly packed to avoid transit damage. Suitable markings shall be provided to identify the goods with that of the PO No. and the consignee details.4. Goods shall be consigned to AGM (CRX), BHEL, Piplani, Bhopal - 462022, India, unless otherwise specified in the PO.
12	Pricing Terms
12.1	Prices once quoted shall remain firm within the validity or any extension thereof for placement of order, till complete execution of the order, without any escalation/increase for any reason, whatsoever, unless specifically provided for in the Enquiry & PO. In case of foreign bidders, the quoted price shall be taken as inclusive of Third Party Inspection and testing charges as called for in the NIT.
13	Price Validity :
13.1	Unless stated otherwise in the enquiry, offer shall be valid for a period of 90 days from the date of Techno- commercial (Part-I) bid opening date.
14	Taxes & Duties - Indigenous Purchase
14.1	Bidder to ensure timely remittance of SGST, CGST, IGST as applicable in time as per law.
14.2	Bidder to ensure compliance to filing of monthly GST sales return including BHELs supplies by 10 th of next calendar month in the online GST portal wherever applicable.
14.3	Bidders to declare filing of timely returns and GST remittance/likely remittance /ITC adjustment along with invoice.
14.4	Bidder to submit invoices compliant with GST invoice Rules
14.5	Bidders to comply with all statutory provisions as may be applicable at the time of despatch/sale. Any additional financial liability to BHEL on account of non-compliance by bidders shall be borne by them and shall be adjusted / recovered from the bidders. BHEL reserves the right to review the existing offers / contracts for any revision in terms, which may arise due to change in any statutory provisions to ensure that the benefit accrues to BHEL.
14.6	Bidder to ensure TAX INVOICE submission along with consignment
14.7	In respect of cases where the liability to discharge GST is on BHEL under reverse charge mechanism, bidders have to ensure timely submission of invoices and delivery of material / services to BHEL, so that there is no mismatch on both activities. In case there is any additional financial liability on BHEL on account of default on the part of the bidder on submission or delivery of material / services the same shall be passed on to them.
14.8	Vendors who fall under the E-Invoice regulations shall issue e-invoice in line with Rule 48(4) of CGST Rules read along with latest extant rules, failing which GST amount will not be reimbursed to the vendor.
14.9	In respect of free issue material by BHEL, bidders have to return the processed material within the time line as per the provisions of GST. In case of any additional tax liability on BHEL on account of non-compliance by the bidder, the additional financial implications on BHEL shall be passed on to the bidder
14.10	Bidders to provide the applicable HSN / SAC codes as called for in the enquiry
14.11	As per provisions of section 171 of the CGST Act 2017, bidders to pass on the anti-profiteering benefits accruing to them under GST regime to BHEL
14.12	With reference to section 51 of CGST act 2017 read with notification no 50/2018 – Central tax dated 13.09.2018; BHEL will be liable to deduct TDS under GST with effect from 01.10.2018. Deduction shall be made @ 2% (1% CGST + 1% SGST) or 2% IGST (as applicable) of the payment made or the amount credited. Bidder to generate & submit invoices as per above.



BP 200102B

HEAVY ELECTRICALS PLANT, BHOPAL

GENERAL TERMS AND CONDITIONS OF ENQUIRY

	<p>The amount of TDS shall be deposited to the Government account and BHEL shall issue TDS certificate to deductees, TDS deposited in the Government account will be reflected in the electronic cash ledger of the deductee who will be able to use the same for payment of tax or any other amount.</p> <p>Deduction of TCS along with additional TDS will be as per prevailing Government guidelines.</p>			
15.	Taxes & Duties - Foreign Purchase – Imports			
15.1	The offered prices shall be inclusive of all the Taxes and duties as applicable in the country of bidder / country of dispatch for the quoted CFR / CIF price.			
16	Payment Terms-			
16.1	Indigenous: 100% payment in 90 days of receipt (45 days for Micro & Small and 60 days for Medium enterprises as registered in Udyam certificate as per relevant MSME act in force) and subject to acceptance of material and relevant documents at BHEL. In case of despatch of material to site directly, site certification for receipt of materials is required unless otherwise provided for in the PO. Any deviation from the above payment terms, if accepted (by BHEL), shall be loaded @ SBI base rate + 6% for the purpose of bid evaluation.			
16.2	Foreign: 100% against irrevocable, unconfirmed LC, payable within 90 days of the Bill of Lading (B/L) date or Payment terms of CAD payable on 90 th day of B/L / AWB. In case BHEL considers any deviation in payment terms i.e. early payment based on bidder's request, then bids shall be evaluated with loading of State bank of India Base rate plus 6%, for the credit period short of 90 days. The LC shall be established 2 months prior to shipment date, valid for period of 90 days, unless agreed otherwise.	Documents to be submitted as per UCP600 and should reach BHEL/ BHEL's bank at least 7 days prior to vessel arrival.		
16.3	Staggered Payment terms in case of Capital items /Balance of plant (BOP) item where services of installation /erecting & commissioning /supervision is desired with supply of items /goods will be separately mentioned in particular tender remarks /Special terms & condition /Additional terms and condition			
16.4	Foreign bidders to submit declaration of Permanent Establishment and Business Connection (PEBC) for remittances purpose. Declaration to be submitted in formats either in Annexure A or B whichever is applicable as per their transaction entered into with BHEL.	In the absence of certificates from the bidder, withholding tax at applicable rates along with surcharge and cess will be recovered at the time of remittance to the bidder.		
16.5	Foreign bidders to submit Tax Residency Certificate (TRC) & Form 10F (for obtaining DTAA benefits) as per Annexure C in respect of services. The TRC (tax residency certificate) is to be issued by the authorities of the government of bidder's country. If the informative part of the format (other than residency) is not furnished by the authorities the same may be furnished by the bidder as a declaration.			
16.6	BHEL Bhopal is registered with (TReDS) platform. MSME bidders are requested to get registered with (TReDS) platform to avail the facility as per the GOI guidelines.			
17	Inspection of Goods			
17.1	The Bidder shall give adequate notice, of 1 week or as mutually agreed period, in writing to the Purchaser (in case Customer inspection is involved) or BHEL appointed TPIA about the date and place at which the goods will be ready for inspection/ testing, as provided for in the contract.			
17.2	Purchaser or his authorized representative shall be entitled to carry out inspection of material and workmanship/Surveillance Audit at Bidder's premises or at his sub-contractor's premises at all reasonable times during execution of contract; Such inspection, examination and testing, if made, shall not absolve the Bidder from his obligations under the contract.	Wherever required, BHEL may carry out testing at BHEL's testing Lab and in case of any rejection during such testing, replacement / rectification, as required, will have to be done by Supplier.	If BHEL carries out any rectification of such rejected material, such cost will be recovered from Supplier's Bills.	In case of Customer inspection as Supplier's Works, inspection clearance to be obtained from Customer and submitted to BHEL.
17.3	BHEL's representative from unit or Corporate Quality (CQ) is authorised to carry out audits along with TPIA at bidder's works before clearing the items for despatch.			
17.4	All costs related to inspections and re-inspections shall be borne by the Bidder. In case of inspection by BHEL and / or BHEL's customer, the cost of to & fro passage and Boarding & Lodging shall be borne by the Purchaser / Customer, unless otherwise specifically agreed. In case of foreign bidders, the cost of third party inspection, where called for, shall be deemed to be included in the quoted price. Bidder shall be responsible to provide assistance such as labour, materials, electricity, fuels, stores, apparatus, instruments at his cost, as may be required and as may be reasonably demanded to carry out such tests effectively.			
17.5	REJECTION: If any goods are rejected, BHEL shall be at liberty to take action as per following:			



BP 200102B

HEAVY ELECTRICALS PLANT, BHOPAL

GENERAL TERMS AND CONDITIONS OF ENQUIRY

	<p>a) Allow the supplier, wherever mutually agreed, to rectify the rejected goods at BHEL's works within reasonable time as fixed by BHEL.</p> <p style="text-align: center;">Or</p> <p>b) Allow the supplier to make free replacement within a specified period. Rejected goods can be lifted by the supplier thereafter.</p> <p style="text-align: center;">Or</p> <p>c) In case payment has been done, allow supplier to refund equivalent value of rejected material by NEFT / RTGS or furnish Bank Guarantee for same amount before lifting the rejected goods. Fresh replacement shall be regulated as per terms and condition of the original Purchase Order. In case payment has not been done, at instructions from BHEL, supplier has to rectify the rejected goods at supplier's works within reasonable time as fixed by BHEL.</p> <p style="text-align: center;">Or</p> <p>d) Terminate the contract either in part or in whole at the discretion of BHEL and invoke Breach of Contract clause, if any, from the supplier.</p> <p style="text-align: center;">Or</p> <p>e) Any goods rejected by BHEL must be removed by the supplier after making payment through NEFT / RTGS within 30 days after receipt of the intimation of rejection. If bidder fails to lift or allow despatch of rejected material at his cost within 90 days from the intimation of rejection, his claim on rejected material shall cease.</p> <p style="text-align: center;">Or</p> <p>f) In exceptional cases, allow the supplier for one-time replacement of defective items (quantity) within reasonable time.</p>
18	Guarantee / Warranty and corresponding Repairs / Replacement of Goods
18.1	<p>Manufacturer's works test/inspection certificates shall be furnished along with the guarantee that material conforms strictly to the specification for general & special conditions as laid down in the purchase order. Goods shall comply with the specifications for material, workmanship and performance. The warranty shall be for a period of 12 months from the date of receipt. If the delivery is found non-compliant during the warranty period, leading to rejection, the Bidder shall arrange free replacement / repair of goods, within one month from the date of intimation or any mutually agreed period. The rejected goods shall be taken away by the Bidder at his cost and replaced on Delivered Duty Paid (DDP) (FOR - BHEL Stores/ designated destination basis) within such period. In the event of the Bidder's failure to comply, Purchaser may take action as appropriate, including Repair / Replenish rejected goods & disposal of rejections, at the risk & cost of the Bidder.</p> <p>In case the defects attributable to Bidder are detected during processing of the goods at purchaser's / his subcontractor's works, the Bidder shall be responsible for free replacement/ repair of the goods as required by the purchaser.</p>
19	<p>NOTE: Deviations (Commercial as well as Technical) from the tender specifications and conditions are generally not acceptable. However, deviation if any, shall be brought out clearly with proper justification in the offer. The deviation, if considered by BHEL shall be loaded for comparison, while evaluating the offer. If a bidder unconditionally withdraws any deviation before price bid opening, the same shall not be loaded. Loading criteria in respect of major commercial conditions where deviations if any are accepted shall be as per clause No.19.</p>
19.1	Evaluation and Loading Criteria:
19.1.1	<p>The evaluation currency for this tender shall be INR.</p> <p>Evaluation of the tender shall be on the basis of delivered cost, i.e. 'Total Cost to BHEL/Landed cost to BHEL ' w.r.t the technical scope and commercial conditions finalized after techno-commercial clarifications (after considering, inter alia, Customs Duty and GST / Other taxes as applicable). Exchange rate (TT selling rate of State Bank of India) applicable on the date of Part-I bid opening shall be considered for evaluation of foreign bids. If the relevant day happens to be a bank holiday in India, then the FOREX rate as on the previous bank working day shall be taken for evaluation.</p> <p>Foreign suppliers shall ensure that the benefits as applicable under Comprehensive Economic Partnership Agreement (CEPA) with Government of India are disclosed in the bid & relevant documents such as Certificate of Country of Origin, issued by the appropriate authority in the country of Export, is provided by the bidder along with dispatch documents. Bids shall be evaluated with such applicable benefits. In the event of Bidder failing to provide appropriate documents for Purchaser to avail disclosed concessional duty benefits in India, financial loss, so incurred, will be to the Bidder's account.</p>
19.1.2	<p>Common Loading factors (in case of deviation quoted by bidders)</p> <p>INDIGENOUS</p> <ol style="list-style-type: none"> 1) Deviation quoted in delivery terms in EX works against FOR destination: In case BHEL accepts the EX-Works prices, such offers will be suitably loaded with actual freight charges as per BHEL freight rate contract. 2) Loading (if any) in case of deviation in delivery period in delivery non- sensitive contracts will be declared separately in STC/ATC of particular tenders.



BP 200102B

HEAVY ELECTRICALS PLANT, BHOPAL

GENERAL TERMS AND CONDITIONS OF ENQUIRY

	<p>IMPORTS</p> <p>1) Offer received on FOB/FCA basis may be considered on an exceptional basis. BHEL will load freight, marine insurance & shipping line port handling charges etc. to work out landed cost at Sea Port.</p> <p>2) Import duty, Taxes and duties as applicable on the date of Part-I bid opening.</p> <p>COMMON LOADING FOR IMPORTS & INDIGENOUS that will be added for arriving the "Total Cost to BHEL"</p> <p>A. Loading on Deviated Penalty clause (LD) as per clause 9.1.14 of GTC</p> <p>B. Loading for payment terms as per clause 16.1 of GTC</p>
20	Variation of orders
20.1	No variation to the Purchase order is permitted unless authorised in writing and signed by or on behalf of purchase executive, BHEL Bhopal.
21	Sub-contract
21.1	BHEL's order or part there off, if further to be subcontracted in exceptional circumstances the details of subcontracting and to whom to be subcontracted shall be furnished to BHEL and written permission shall be obtained from BHEL. However, it shall not absolve the supplier of the responsibility of fulfilling BHEL order requirements.
22	Recovery / deductions of amount from supplier
22.1	<p>a Any amount on account of recovery from consignor / supplier under any condition shall be liable to be adjusted against any amount payable to the consignor/supplier against bills.</p> <p>b For any deficiency in supplies where deduction is involved, an amount as decided by BHEL, shall be deducted from supplier's bills.</p>
23	Safety clause for purchase orders
23.1	<p>The bidders shall maintain and ensure sufficient safety measures as required for inspections and test like HV test. Pneumatic test, Hydraulic test Spring test, Bend test, Material handling and safe working environment etc. to enable Inspection Agency for performing inspection.</p> <p>The bidder shall ensure that all the safety precautions specified in factories Act 1948 chapter-IV Section-21 to 41 are complied with respect to equipment's to be inspected.</p> <p>If any test equipment is found not complying with proper safety requirement, then the inspection agency may withhold inspection, till such time the desired safety requirements are met.</p>
24	Non-Disclosure Agreement
24.1	<p>All Drawing and technical documents relating to the product or it's manufacture submitted by one party to the other, prior or subsequent to the formation of contract, shall remain property of the submitting party. Drawing, technical documents or other technical information received by one party, shall not without the consent of the other party, be used for any other purpose than that, for which they were provided. Such technical information shall not without the consent of the submitting party, otherwise be used or copied, reproduced, transmitted or communicated to a third party. Patterns supplied by BHEL will remain BHEL's property which shall be returned by the bidder on demand to BHEL. Bidder shall in no way share or use such intellectual property of BHEL to promote his own business with others. <u>BHEL reserves the right to claim damages from the bidder, or take appropriate penal action as deemed fit against the bidder, for any infringement of the provisions contained herein.</u></p>
	<p>DRAWINGS, PATTERNS & TOOLS: All drawings, patterns & tools supplied by BHEL or made at BHEL's expense are BHEL's property. These cannot be used or referred to any other party and must only be used in the execution of BHEL's orders. These should be preserved at the supplier's cost for a period of not less than 5 years. Patterns & tools should be returned to BHEL within 90 days of issue of the same.</p>
25	Settlement of Disputes & Arbitration
25.1	All questions/interpretations regarding subject matter of the Contract shall be decided by the Purchaser on the request of the Bidder and the decision of the Purchaser shall be final.
25.2	In case of dispute, steps shall be taken by the parties to the contract to settle the same through negotiations.
25.3	In case, dispute is not settled in negotiations, it shall be referred to Conciliator appointed by the competent authority of the Purchaser.
25.4	<p>Except as provided elsewhere in this Contract, in case amicable settlement is not reached between the Parties, in respect of any dispute or difference; arising out of the formation, breach, termination, validity or execution of the Contract; or, the respective rights and liabilities of the Parties; or in relation to interpretation of any provision of the Contract; or, in any manner touching upon the Contract, then, either Party may, by a notice in writing to the other party refer such dispute or difference to the sole arbitration of an arbitrator appointed by Head of the BHEL Unit/Region/Division issuing the Contract.</p> <p>The Arbitrator shall pass a reasoned award and the award of the Arbitrator shall be final and binding upon the Parties. Subject as aforesaid, the provisions of Arbitration and Conciliation Act 1996 (India) or Statutory modifications or re-enactments thereof and the rules made thereunder and for the time being in force shall apply to the arbitration proceedings under this clause. The seat of arbitration shall be Bhopal.</p>



BP 200102B

HEAVY ELECTRICALS PLANT, BHOPAL

GENERAL TERMS AND CONDITIONS OF ENQUIRY

	<p>The cost of arbitration shall be borne as per award of the Arbitrator.</p> <p>Subject to the arbitration in terms of Clause above, the Courts at Bhopal shall have exclusive jurisdiction over any matter arising out of or in connection with this Contract.</p> <p>Notwithstanding the existence or any dispute or differences and /or reference for the arbitration, the Contractor shall proceed with and continue without hindrance the performance of its obligations under this Contract with due diligence and expedition in a professional manner except where the Contract has been terminated by either Party in terms of this Contract. Administrative Mechanism for Resolution of CPSEs Dispute as stated in https://dpe.gov.in/guidelines/guidelines/chapters/2673.</p> <p>In the event of any dispute or difference relating to the interpretation and application of the provisions of the commercial Contract between Central Public Sector Enterprises (CPSEs)/Port Trusts inter-se and also between CPSEs and Government Departments/Organizations (excluding disputes concerning railways, Income Tax, Customs and Excise Departments), such dispute or difference shall be taken up by either party for resolution through Administrative Mechanism for Resolution of CPSEs Disputes (AMRCD) as mentioned in Department of Public Enterprises (DPE) Office Memorandum No. 4(1)/2013-DPE(GM)/FTS-1835 dated 22-05-2018 as amended from time to time."</p>
25.5	The Bidder shall continue to perform the contract, pending settlement of dispute(s).
26	Applicable Laws and Jurisdiction of Courts
26.1	Indian laws both substantive and procedural, for the time being in force, including modifications thereto, shall govern the Contract including Arbitration proceedings. The competent Courts at Bhopal in the State of Madhya Pradesh, India shall have sole jurisdiction.
27	RIGHT OF REJECTION /NON- PLACEMENT OF PO: BHEL reserves the right to accept the offers in part or in full, or cancel the Tender enquiry without assigning any reason.
28	Performance Bank Guarantee (PBG)/ Security Deposit (SD):
28.1	<p>Wherever Security Deposit (covering contract performance) is called for in the Tender /NIT , the Performance Bank Guarantee (PBG) or Security Deposit (SD), hereafter referred as performance security is to be submitted by the successful bidder awarded the contract.. Performance security is to be submitted by the date specified in the contract.</p> <p>Modes of deposit:</p> <p>a) Performance security may be furnished in the following forms:</p> <p>(i) Local cheques of Scheduled Banks (subject to realization)/ Pay Order/ Demand Draft/ Electronic Fund Transfer in favour of BHEL.</p> <p>(ii) Bank Guarantee from Scheduled Banks / Public Financial Institutions as defined in the Companies Act. The Bank Guarantee format should have the approval of BHEL.</p> <p>(iii) Fixed Deposit Receipt issued by Scheduled Banks / Public Financial Institutions as defined in the Companies Act (FDR should be in the name of the Contractor, a/c BHEL).</p> <p>(iv) Securities available from Indian Post offices such as National Savings Certificates, Kisan Vikas Patras etc. (held in the name of Contractor furnishing the security and duly endorsed/ hypothecated/ pledged, as applicable, in favour of BHEL).</p> <p>(v) Insurance Surety Bond.</p> <p>(Note: BHEL will not be liable or responsible in any manner for the collection of interest or renewal of the documents or in any other matter connected therewith)</p> <p>b) In case of GTE tenders, the performance security should be in the same currency as the contract and must conform to Uniform Rules for Demand Guarantees (URDG 758) - an international convention regulating international securities.</p> <p>a) Performance Security is to be furnished by a specified date (generally 14(fourteen) days after notification of the award) and it should remain valid for a period of 60 (sixty) days beyond the date of completion of all contractual obligations of the supplier, including warranty obligations.</p> <p>Forfeiture of Performance Security:</p> <p>The performance security will be forfeited and credited to BHEL's account in the event of a breach of contract by the supplier.</p> <p>PS shall be refunded to the contractor without interest, after he duly performs and completes the contract in all respects but not later than 60 (sixty) days of completion of all such obligations including the warranty under the contract.</p> <p>The Performance Security shall not carry any interest.</p>
28.2	Composite 'Contract Performance Bank Guarantee' of matching value/ validity, where both Security Deposit and Performance Bank Guarantee are required, shall not be construed as deviation.
28.3	Wherever the contract is for supply of Goods processed on labor basis/mixed basis from BHEL supplied materials, the materials shall be issued against a suitable Bank guarantee as specified in the particular Enquiry/STC/ATC/Annexures.
28.4	Wherever PBG (covering equipment / system / work performance guarantee) is called for in the Notice Inviting Tender (NIT) deviation shall not be accepted



BP 200102B

HEAVY ELECTRICALS PLANT, BHOPAL

GENERAL TERMS AND CONDITIONS OF ENQUIRY

28.5	Bank Guarantee wherever called for, shall be in the BHEL prescribed format. In case the order is to be placed in foreign currency, the BG must also be in Foreign currency, so specified by the Purchaser
28.6	Wherever Security Deposit (covering contract performance) is called for in the NIT, deviation shall not be accepted.
28.7	Bidder agrees to submit performance security required for execution of the contract within the time period mentioned. In case of delay in submission of performance security, enhanced performance security which would include interest (SBI rate + 6%) for the delayed period, shall be submitted by the bidder. Further, if performance security is not submitted till such time the first bill becomes due, the amount of performance security due shall be recovered as per terms defined in NIT / contract, from the bills along with due interest
29	<p>Benefits earmarked for Purchase from Micro & Small Enterprises (MSEs) –</p> <p>All benefits as per Government of India guidelines shall be given to eligible bidders.</p> <p>MSE bidders as defined by the MSMED Act as amended from time to time can avail the intended benefits only if they submit along with the offer, self-attested copies of relevant document, Udyam Registration as applicable stipulated in the MSMED Act or its rules/ regulations as amended from time to time and /or by the buyer. Non submission of such documents as stipulated hereinbefore will lead to consideration of their bids at par with other bidders. No benefit shall be applicable for the concerned for the tender enquiry, if any deficiency in the above required documents is not submitted before the price bid opening. If the tender is to be submitted through e-procurement portal, then the above required documents are to be uploaded on the portal. This provision for MSE will apply subject to the condition that the participating MSE meets the tender requirements.</p> <p>In case of any change in the MSE status of the bidder, it shall be the responsibility of the bidder to notify the change as a part of the bid document. If at a later date it comes to the knowledge of BHEL, that the change in the status has not been intimated by the bidder and the order is obtained under the premise of an MSE then BHEL may reject the bid or, as the case may be, cancel the order and take necessary steps for suspension of the business dealing against the bidder as per the extant guidelines for suspension of business dealings with suppliers/ contractors of BHEL.</p> <p>Note: MSME benefits shall not be given to traders, Dealers or authorised agents.</p> <p>It may however be noted that MSE guidelines as on date (Date of Technical Bid Opening Part-1) shall prevail.</p> <p>As per the OM No. F. No. 1(2)(1)/2016-MA dtd. 09.02.2017 issued from the Office of Development Commissioner (Micro, Small & Medium Enterprises), "Traders and agents should not be allowed to avail the benefits extended under the PP Policy". In view of this, it is clarified that benefits of MSE (such as EMD Waiver, Tender fee exemption, Price preference, Payment preference etc.) will be given only to those MSE Vendors who are manufacturers of offered items against the NIT. No MSE benefits shall be provided to Agents / Stockists / Dealers / Traders etc. for the items offered but not manufactured by themselves.</p>
29.1	MSEs shall be given tender documents free of cost and shall be exempted from payment of EMD. Tender documents shall be issued free of cost & no EMD wherever called for will be insisted upon. MSE bidders shall submit along with bid relevant documents w.r.t. their respective MSE status as per extant norms. Date to be reckoned for determining the deemed validity will be the last date of Technical bid submission. Non- submission of such document will lead to consideration of their bid, at par with other bidders and MSE status of such bidders shall be shifted to Non- MSE supplier till the supplier submit these documents.
29.2	<p>In tender, participating MSEs quoting price within price band of L1+15% shall also be allowed to supply a portion of requirement by bringing down their price to L1 price in a situation where L1 price is from someone other than a MSE and such MSE shall be allowed to supply up to at least 25% of total tendered value. In case of more than one such MSE, the supply shall be shared proportionately.</p> <p>A quantum of 6.25% (25% out of target of 25%), so earmarked, will be reserved for MSE's owned by SC / ST entrepreneurs who submit their bid with relevant documents provided that in event of failure of such MSE(s) to participate in tender process or meet tender requirements and L1 price, 6.25% sub-target for procurement earmarked for MSE(s) owned by SC or ST entrepreneurs shall be met from other MSE(s).</p> <p>A quantum of minimum of 3% reservation within the above mentioned 25% reservation, so earmarked, will be reserved for MSE's owned by women entrepreneurs who submit their bid with relevant documents provided that in event of failure of such MSE(s) to participate in tender process or meet tender requirements and L1 price, 3% sub-target for procurement earmarked for MSE(s) owned by women entrepreneurs shall be met from other MSE(s).</p> <p>In case of indivisible tender, the full quantity shall be awarded to L1.</p>
29.3	If an enterprise falling under MSE category as defined in the MSMED Act 2006, graduates to a higher category from its original category or beyond the purview of the Act, it shall continue to avail all non-tax benefits of its original category notified by the Ministry of Micro, Small and Medium Enterprise for a period of three years from the date of such graduation to the higher category.
29.4	MSE bidders as defined by the MSMED Act as amended from time to time can avail the intended benefits only if they submit, self-attested copies of Udyam Registration certificate, along with the offer. No benefits shall be applicable for the enquiry if any deficiency in the above required documents are not submitted before price bid opening. If the tender is to



BP 200102B

HEAVY ELECTRICALS PLANT, BHOPAL GENERAL TERMS AND CONDITIONS OF ENQUIRY

	<p>be submitted through e-procurement portal, then the above required self-attested documents are to be uploaded on the portal.</p> <p>No benefits shall be applicable for this enquiry if any deficiency in the above required documents are not submitted before price bid opening. If the tender is to be submitted through e-procurement portal, then the above required self-attested documents are to be uploaded on the portal.</p> <p>The deemed validity will be assessed on the date of bid opening (Part 1 in case of two part bid). Non submission of such documents as stipulated hereinbefore will lead to consideration of their bids at par with other bidders. No benefit shall be applicable for the concerned for the tender enquiry, if any deficiency in the above required documents is not submitted before the price bid opening. This provision for MSE will apply subject to the condition that the participating MSE meets the tender requirements.</p> <p>In case of any change in the MSE status of the bidder, it shall be the responsibility of the bidder to notify the change as a part of the bid document. If at a later date it comes to the knowledge of BHEL, that the change in the status has not been intimated by the bidder and the order is obtained under the premise of an MSE then BHEL may reject the bid or, as the case may be, cancel the order and take necessary steps for suspension of the business dealing against the bidder as per the extant guidelines for suspension of business dealings with suppliers/ contractors of BHEL.</p> <p>In case if all the items being procured under the enquiry fall under category of reserved items as defined in “Public Procurement Policy for Micro and Small Enterprises (MSEs) Order, 2012” and if any of the MSE bidder(s) is techno-commercially qualified then the price bids of only MSE bidders shall be opened. If no MSE bidder is techno-commercially qualified, then price bids of all techno-commercially qualified bidders shall be opened.</p>																								
30	<p>Integrity Pact (IP) — Independent external monitors (IEM) For tenders in which integrity pact is applicable, following points stand valid :</p>																								
20.1	<p>IP is a tool to ensure that activities and transactions between the company and its bidders/contractors are handled in a fair, transparent and corruption free manner. A panel of Independent External Monitors (IEMs) have been appointed to oversee implementation of IP in BHEL.</p> <p>The IP as enclosed with the tender is to be submitted (duly signed by authorized signatory who signs in the offer) along with techno commercial bid. Only those bidders who have entered into such an IP with BHEL would be competent to participate in the bidding. In other words, entering into this pact would be a preliminary qualification.</p> <p style="margin-left: 40px;">Name: ----- Address: ----- E-mail : -----</p> <div style="margin-left: 400px;">} As indicated in NIT / enquiry</div>																								
30.2	<p>Please refer section 8 of the IP for roles and responsibilities of IEMs. In case of any complaint arising out of tendering process, the matter may be referred to the IEM mentioned in the tender.</p> <p>NOTE: No routine correspondence shall be addressed to the IEM (phone / post/e-mail) regarding the clarifications, time extensions or any other administrative queries, etc. on the tender issued. All such clarifications/ issues shall be addressed directly to the tender issuing (procurement) department.</p> <p>For all clarifications/ issues related to the tender, please contact:</p> <table border="1" style="width: 100%; border-collapse: collapse; margin-left: 40px;"> <thead> <tr> <th style="width: 60%;"></th> <th style="width: 20%; text-align: center;">(1)</th> <th style="width: 20%; text-align: center;">(2)</th> </tr> </thead> <tbody> <tr> <td>Name</td> <td></td> <td></td> </tr> <tr> <td>Landline No.</td> <td></td> <td></td> </tr> <tr> <td>Mobile No.</td> <td></td> <td></td> </tr> <tr> <td>Email</td> <td></td> <td></td> </tr> <tr> <td>Dept.</td> <td></td> <td></td> </tr> <tr> <td>Address</td> <td></td> <td></td> </tr> <tr> <td>Fax</td> <td></td> <td></td> </tr> </tbody> </table>		(1)	(2)	Name			Landline No.			Mobile No.			Email			Dept.			Address			Fax		
	(1)	(2)																							
Name																									
Landline No.																									
Mobile No.																									
Email																									
Dept.																									
Address																									
Fax																									
31	<p>Fraud Prevention Policy : The Bidder along with its associate/ collaborators/ sub-contractors/ sub-bidders/ consultants/ service providers shall strictly adhere to BHEL Fraud Prevention Policy displayed on BHEL website www.bhel.com and shall immediately bring to the notice of BHEL Management about any fraud or suspected fraud as soon as it comes to their notice.</p>																								
32	<p>Integrity Commitment: The offers of the bidders who are under suspension as also the offers of the bidders, who engage the services of the banned firms, shall be rejected. The list of banned firms is available on BHEL website www.bhel.com.</p> <p>Integrity commitment, performance of the contract and punitive action thereof :</p>																								
32.1	<p>Commitment by BHEL: BHEL commits to take all measures necessary to prevent corruption in connection with the tender process and execution of the contract. BHEL will during the tender process treat all bidder(s) in a transparent and fair manner, and with equity.</p>																								
32.2	<p>Commitment by bidder / Supplier / Contractor :</p>																								



BP 200102B

HEAVY ELECTRICALS PLANT, BHOPAL

GENERAL TERMS AND CONDITIONS OF ENQUIRY

32.2.1	<ul style="list-style-type: none"> - The bidder / supplier / contractor commit to take all measures to prevent corruption and will not directly or indirectly influence any decision or benefit which he is not legally entitled to nor will act or omit in any manner which tantamount to an offence punishable under any provision of the Indian Penal code, 1860 or any other law in force in India. - The bidder / supplier / contractor will, when presenting his bid, disclose any and all payments he has made, and is committed to or intends to make to agents, brokers or any other intermediaries in connection with the award of the contract and shall adhere to relevant guidelines issued from time to time by govt. of India / BHEL - The bidder / supplier / contractor will perform / execute the contract as per the contract terms & conditions and will not default without any reasonable cause, which causes loss of business / money / reputation to BHEL.
32.2.2	<p>If any bidder / supplier / contractor during pre-tendering / tendering / post tendering / award / execution / post-execution stage indulges in mal-practices, cheating, bribery, fraud or / and other misconduct or formation of cartel so as to influence the bidding process or influence the price or acts or omits in any manner which tantamount to an offence punishable under any provision of the Indian Penal Code, 1860 or any other law in force in India, then action may be taken against such bidder / supplier / contractor as per the extant guidelines of the company available on www.bhel.com and / or under applicable legal provisions.</p>
32.2.3	<p>Preventive checks to eliminate suspected cartel formation between suppliers The Bidder declares that they will not enter into any illegal or undisclosed agreement or understanding, whether formal or informal with other Bidder(s). This applies in particular to prices, specifications, certifications, subsidiary contracts, submission or non-submission of bids or any other actions to restrict competitiveness or to introduce cartelization in the bidding process. In case, the Bidder is found having indulged in above activities, suitable action shall be taken by BHEL as per extant policies/ guidelines</p> <p>Declaration by Bidders We declare that the following family firms or sister concern affiliates/ subsidiary firms are participating in the tender No _____</p> <p>1.0 _____ 2.0 _____ 3.0 _____</p> <p>I _____ hereby declare on behalf of M/s _____ and family firms or sister concern affiliates/ subsidiary firms listed above that we are not indulging in cartel formation for Enquiry No _____.</p> <p style="text-align: right;">(_____) For M/s _____ Seal and Sign</p>
33	<p>Public Procurement (Preference to Make in India), Order 2017 For this procurement, Public Procurement (Preference to Make in India), Order 2017 Dtd 15.06.2017 and 28.05.2018 and subsequent orders issued by both DPIIT and the respective nodal ministries shall be applicable For this procurement, the local content to categorise a supplier as a Class I local supplier/ Class II local Supplier / Non-Local supplier is as defined in Public Procurement (Preference to Make in India), Order 2017 dated 04.06.2020 issued by DPIIT. In case of subsequent orders issued by the nodal ministry changing the definition of local content for the items of the NIT, the same shall be applicable even if issued after issue of this NIT, but before opening of Part-II bids against this NIT.</p> <p>Bidder to mention the percentage of local content and place of value addition to manufacture these items in the tender.</p>
34	<p>RESTRICTION UNDER RULE 144 (xi) OF THE GENERAL FINANCIAL RULES 2017: As per latest government guidelines</p>
34.1	<p>Any bidder from a country which shares a land border with India will be eligible to bid in this tender only if the bidder is registered with the competent authority.</p>
34.2	<p>"Bidder" (including the term 'tenderer', 'consultant' or service provider' in certain contexts means any person or firm or company, including any member of a consortium or joint venture (that is an association of several persons, or firms or companies) every artificial juridical person not falling in any of the description of bidders stated hereinbefore, including any agency, branch or office controlled by such person, participating in procurement process.</p>
34.3	<p>Bidder from a country which shares a land border with India" for the purpose of this order means: -</p> <ol style="list-style-type: none"> a. An entity incorporated, established or registered in such a country; or b. A subsidiary of an entity incorporated, established or registered in such a country; or c. An entity substantially controlled through entities incorporated, established or registered in such a county; or d. An entity whose beneficial owner is situated in such a country; or



BP 200102B

HEAVY ELECTRICALS PLANT, BHOPAL

GENERAL TERMS AND CONDITIONS OF ENQUIRY

	<p>e. An Indian (or other) agent of such an entity; or</p> <p>f. A natural person who is a citizen of such a country; or</p> <p>g. A consortium or joint venture where any member of the consortium or joint venture falls under any of the above.</p>
34.4	<p>The beneficial owner for the purpose of (iii) above will be as under:</p> <ol style="list-style-type: none"> 1. In case of company or Limited Liability Partnership, the beneficial owner is the natural person(s), who, whether acting alone or together, or through one or more juridical person, has a controlling ownership interest or who exercises control through other means. Explanation – <ol style="list-style-type: none"> a. "Controlling ownership interest" means ownership of or entitlement to more than twenty-five per cent of shares or capital or profits of the company. b. "Control" shall include the right to appoint majority of the directors or to control the management or policy decisions including by virtue of their shareholding or management rights or shareholder's agreements or voting agreements. 2. In case of a partnership firm, the beneficial owner is the natural person(s) who, whether acting alone or together, or through one or more juridical person, has ownership of entitlement to more than fifteen percent of capital or profits of the partnership; 3. In case of an unincorporated association or body of individuals, the beneficial owner is the natural person(s), who, whether acting alone or together, or through one or more juridical person, has ownership of or entitlement to more than fifteen percent of the property or capital or profits of such association or body of individuals; 4. Where no natural person is identified under (1) or (2) or (3) above, the beneficial owner is the relevant natural person who holds the position of senior managing official; 5. In case of a trust, the identification of beneficial owner(s) shall include identification of the author of the trust, the trustee, the beneficiaries with fifteen percent or more interest in the trust and any other natural person exercising ultimate effective control over the trust through a chain of control or ownership.
34.5	<p>An Agent is a person employed to do any act for another, or to represent another in dealings with third person.</p>
34.6	<p>Model certificate for Tenders</p> <p><i>"I have read the clause regarding restrictions on procurement from a bidder of a country which shares a land border with India; I certify that this bidder is not from such a country or, if from such a country, has been registered with the competent authority. I hereby certify that this bidder fulfills all requirements in this regards and is eligible to be considered. [Where applicable , evidence of valid registration by the Competent Authority shall be attached]."</i></p>
35	<p>Conflict of Interest:</p> <p>"A bidder shall not have conflict of interest with other bidders. Such conflict of interest can lead to anti-competitive practices to the detriment of Procuring Entity's interests. The bidder found to have a conflict of interest shall be disqualified. A bidder may be considered to have a conflict of interest with one or more parties in this bidding process, if: a) they have controlling partner (s) in common; or</p> <p>b) they receive or have received any direct or indirect subsidy/ financial stake from any of them; or c) they have the same legal representative/agent for purposes of this bid; or</p> <p>d) they have relationship with each other, directly or through common third parties, that puts them in a position to have access to information about or influence on the bid of another Bidder; or</p> <p>e) Bidder participates in more than one bid in this bidding process. Participation by a Bidder in more than one Bid will result in the disqualification of all bids in which the parties are involved. However, this does not limit the inclusion of the components/ subassembly/ Assemblies from. one bidding manufacturer in more than one bid; or</p> <p>f) In cases of agents quoting in offshore procurements, on behalf of their principal manufacturers, one agent cannot represent two manufacturers or quote on their behalf in a particular tender enquiry. One manufacturer can also authorize only one agent/dealer.</p> <p>There can be only one bid from the following:</p> <ol style="list-style-type: none"> 1. The principal manufacturer directly or through one Indian agent on his behalf; and 2. Indian/foreign agent on behalf of only one principal; or



BP 200102B

HEAVY ELECTRICALS PLANT, BHOPAL GENERAL TERMS AND CONDITIONS OF ENQUIRY

	<p>g) A Bidder or any of its affiliates participated as a consultant in the preparation of the design or technical specifications of the contract that is the subject of the Bid; or</p> <p>h) In case of a holding company having more than one independently manufacturing units, or more than one unit having common business ownership/management, only one unit should quote. Similar restrictions would apply to closely related sister companies.</p> <p>Bidders must proactively declare such sister/ common business/ management units in same/ similar line of business. "</p>
36	<p>Breach of contract, Remedies and Termination</p> <p>In case of breach of contract, wherever the value of security instruments like performance bank guarantee available with BHEL against the said contract is at least 10% of the contract value, the same be encashed. In case the value of the security instruments available is less than 10% of the contract value, the balance amount be recovered from other financial remedies (i.e. available bills of the contractor, retention amount, etc. with BHEL) or legal remedies be pursued. Further, levy of liquidated damages, debarment, termination, de-scoping, short-closure, etc., shall be applied as per provisions of the contract.</p>
37	<p>Option clause:</p> <p>The Purchaser reserves the right to decrease the quantity to be ordered at the time of placement of contract. The purchaser also reserves the right to increase the ordered quantity by up to 25% of the contracted quantity during the currency of the contract at the contracted rates. Bidders are bound to accept the orders accordingly.</p>

Note:

1.0 Tender Specific conditions shall override relevant provisions of this GTC

2.0 In the event of any change as notified by Govt. of India same will supersede the relevant GTC clause.



BHARAT HEAVY ELECTRICALS LIMITED, BHOPAL
QUALITY PLAN FOR –RETAINING RING TO SPEC. BP19381

QUALITY PLAN NO. QA/MT/BOI/099 REV 01

DATE: 02/04/2021

Page : 1 of 2

ABBREVIATION:

V	Visual,
M	Measurement
T	Testing
PV	Process Verification

SL. NO	COMPONENT	CHARACTERISTICS	TYPE OF CHECK	QUANT AM OF CHECK	REFERENCE DOCUMENT	ACCEPTANC E NORMS	FORMA T OF RECORD	REMARKS
1.0		Chemical Analysis	T	Sample/ melt	BP19381	BP19381	TC	Record Review
2.0		Heat Treatment	PV	100%	BP19381	BP19381	Temp. chart	Record Review
3.0		Mechanical properties -Tensile Strength -Impact Value (0.2% Proof Stress, % elongation, % Reduction in Area, Charpy Impact	T	Sample/h eat/heat treatment batch	BP19381	BP19381	TC	Record Review Record Review
4.0		Surface Finish Free from cracks, flakes, seams, segregation, harmful non-metallic inclusion	V	100%	BP19381	BP19381	TC	Record Review
5.0		UT	T	100%	AA0850118	Cat-I- AA0850118/BP 19381	TR	Record Review
6.0		LP	T	100%	BP19381	BP19381	TR	Record Review
7.0		Dimensional inspection	M	100%	Drg./spec/PO	Drg./spec/PO	IR	Record Review



BHARAT HEAVY ELECTRICALS LIMITED, BHOPAL
QUALITY PLAN FOR –RETAINING RING TO SPEC. BP19381

QUALITY PLAN NO. QA/MT/BOI/099 REV 01

DATE: 02/04/2021

Page : 2 of 2

8.0		Packing & Marking Machined surface protection by Anti corrosive compound Marking - Drg.no (on inner surface), supplier name, batch, weight & PO no.	V	100%	Drg./spec/PO	Drg./spec/PO	TC	Record Review
-----	--	--	---	------	--------------	--------------	----	---------------

PREPARED BY:



आजीव मोहन तेलगोटे / A.M. TELGOTE
उप प्रबंधक (गु.आ.) / Dy. Manager (Q.A.)
गुणता आश्वासन सेटर्स / Quality Assurance-Motors
बी.एच.ई.एल., भोपाल / BHEL, BHOPAL

APPROVED BY

एस.एम.डी. लुगुन / S.M.D. LUGUN
अपर महाप्रबंधक (क्यू.ई.एम.) / AGM (QEM)
गुणता नियंत्रण-ईएम / Quality Control-EM
बी.एच.ई.एल., भोपाल / BHEL, BHOPAL

THE INFORMATION ON THIS DOCUMENT IS THE PROPERTY OF BHARAT HEAVY ELECTRICALS LIMITED. IT MUST NOT BE USED DIRECTLY OR INDIRECTLY IN ANY WAY DETRIMENTAL TO THE INTEREST OF THE COMPANY.

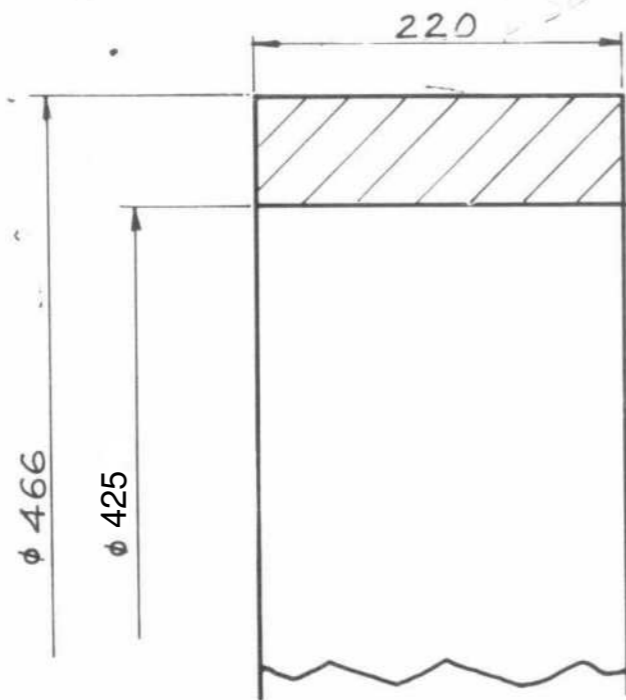
DRG. NO. 34028042012



TECHNICAL REQUIREMENTS:-

- RING TO BE FORGED MEETING PROPERTIES TO BP19383 AND ULTRASONICALLY TESTED AS PER SPEC.
- MACHINE ALL OVER 12.5° .
- SHARP EDGES TO BE REMOVED.

STYLE NO. : BL9084321294

01	RETAINING RING FORGED	50.00
50	VAR. NO.	64
65	REMARKS	75
76	VAR. NO.	78
79	ITEM NO.	26
27	DESCRIPTION	28
58	STD.	59
60	DRAWING NO.	77
29	[IT. NO.]	31
32	VAR.	33
46	MATL. SPCN.	54
55	A	56
57	C	58
UNIT	WT. KG.	65
QTY.		71

ADDITIONAL INFORMATION
W.O. NO.

STATUS OF DRAWING
DISTRIBUTION OF PRINTS
AME -1, IMM-3, TCX (IMM)-1

उत्पाद का प्रकार या ग्राहक/परियोजना का नाम 1LA7 71 2P/1RA7 56 2P
TYPE OF PRODUCT OR NAME OF CUSTOMER/PROJECT

नाम/NAME	स्ता/SIGN.	दि./DATE	वेरि की संख्या NO. OF VAR.
रामलजन सिंह	SD/-	7-8-88	
P. B.	SD/-	8-6-88	

भारत हेवी इलेक्ट्रिकल्स लिमिटेड
BOPAL
BHARAT HEAVY ELECTRICALS LTD.
BHOPAL

REV 04	DATE 20.03.25	ALTD. PKD CHKD. AKM	REV 03	DATE 07.09.19	ALTD. YM CHKD. AKM	REV DATE 02	DATE 27.4.98	ALT. CHKD. CKD.	REV 01	DATE 11.8.95	ALTERED 20	DATE	CHCKED	APPROVED	भाग/DEPT. AME	अनुम. नं./UNTOL. DIMS. GR.	अनुपात/SCALE N.T.S.	भार (कि.ग.)/WEIGHT(K.G.)	असे. ड्राइंग का संदर्भ/REF. TO ASSY DRG.	मद क. ITEM NO.	मद संख्या/NO. OF ITEM
WEIGHT CORRECTED FOR RING I/D 425.		DIM. DIA 425 WAS 433		MAT. CODE BP19383 WAS BP10787		ZONE		DRG. REDRAWN OLD ORIGINAL SCRAPPED. RING WAS 480% ϕ x 420 $\frac{1}{D}$ x 220 LG. FABRICATED.				शीर्षक/TITLE RETAINING RING		ड्राइंग क्र./DRAWING NO. 34028042012		पृष्ठ क्र./SHT.No.		पृष्ठों की सं./NO. OF SHT.		04	

A3 SIZE

DRG. NO. 34028042016

THE INFORMATION ON THIS DOCUMENT IS THE PROPERTY OF BHARAT HEAVY ELECTRICALS LIMITED. IT MUST NOT BE USED DIRECTLY OR INDIRECTLY IN ANY WAY DETRIMENTAL TO THE INTEREST OF THE COMPANY.

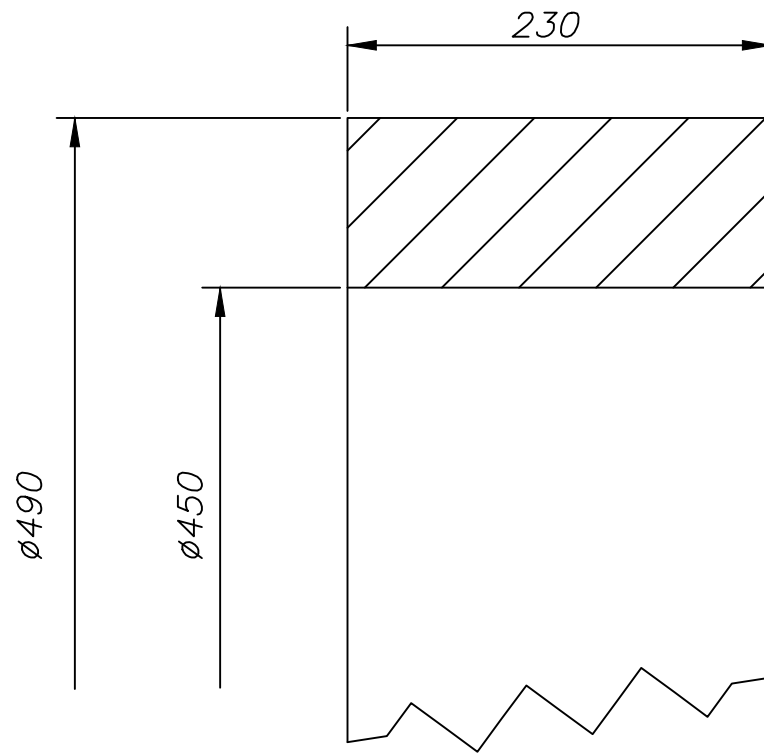

TECHNICAL REQUIREMENTS:-

1. RING TO BE FORGED MEETING PROPERTIES TO BP19383 & ULTRASONICALLY TESTED AS PER SPEC.
2. MACHINE ALL OVER. $\sqrt{12.5}$
3. SHARP EDGES TO BE REMOVED.

STYLE NO. :- BP9504323910

01	SEE T.R.		001	RETAINING RING FORGED															53.50		
59	64	65	75	78	79	25	27	29	58	59	60	77	29	31	34	45	55	56	58	65	72
VAR 01		REMARKS			VAR. NO.	ITEM NO.	DESCRIPTION	STD.	DRAWING NO.			IT. NO.	MATL. CODE		54	55	56	UNIT WT.		65	72
												32	33	46	54	55	56	QTY.		71	78
CARD TYPE-3										CARD TYPE-1										CARD TYPE-2	

ADDITIONAL INFORMATION
W.O. 42197A407-11,21

STATUS OF DRAWING

DISTRIBUTION OF PRINTS
AME - 1, FBM - 4
IMM - 3
GTG (IMM) - 1

TYPE OF PRODUCT OR NAME OF CUSTOMER/PROJECT
1MJ7710-2P

BHARAT HEAVY ELECTRICALS LTD.
BHOPAL

DRN	NAME	SIGN	DATE	NO.OF VAR.
P.SURANGE	-sd-	30.04.93		
V.K.JAIN	-sd-	01.05.93		
V.R.G.	-sd-	01.05.93		

REV.	DATE	ALTD.	BY	REV.	DATE	ALTD.	BY	REV.	DATE	ALTD.	BY
03	18.05.13	K.N.P.-sd-		02	24.04.98	DHOTE -sd-		01	11.08.95	-sd-	
		CHKD. - J.K.-sd-				CHKD. - P.B. -sd-				CHKD. - -sd-	
		APPD. - M.K.M.-sd-				APPD. - P.B. -sd-				APPD. - -sd-	

STYLE NO. ADDED.
DRAWING REDRAWN.

DRAWING REDRAWN. OLD ORIGINAL
SCRAPED.

DRAWING REDRAWN. OLD ORIGINAL
SCRAPED.

DEPT. AME
CODE 404

UNTOL.DIMS.GR.

SCALE NTS

WEIGHT(K.G.)

REF. TO ASSY. DRG.

ITEM NO.

NO.OF ITEMS

TITLE
RETAINING RING

DRAWING NO.
34028042016

REV. 04

SHEET NO. 1 NO. OF SHEETS 1

THE INFORMATION ON THIS DOCUMENT IS THE PROPERTY OF BHARAT HEAVY ELECTRICALS LIMITED.
 IT MUST NOT BE USED DIRECTLY OR INDIRECTLY IN ANY WAY DETRIMENTAL TO THE INTEREST OF THE COMPANY.

DRG. NO. 34028042020

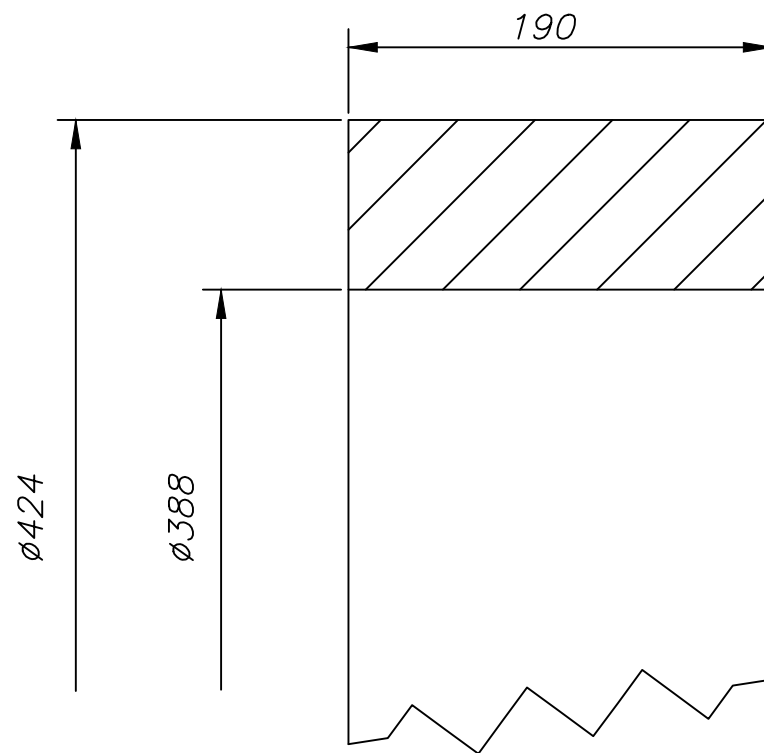

TECHNICAL REQUIREMENTS:-

1. RING TO BE FORGED MEETING PROPERTIES TO BP19383 & ULTRASONICALLY TESTED AS PER SPEC.
2. MACHINE ALL OVER. $\sqrt{12.5}$
3. SHARP EDGES TO BE REMOVED.

STYLE NO. :- BP9504323928

01	SEE T.R.	001	RETAINING RING FORGED																												
										BP 19383																					
59	64	65	75	78	79	25	27	29	58	59	60	77	29	31	34	MATL. CODE	45	55	56	58	UNIT WT.	65	72								
VAR 01										REMARKS										DESCRIPTION		STD.		DRAWING NO.		IT. NO.		MATL. SPECN.		UNIT	
28										CARD TYPE-3										28		CARD TYPE-1		28		CARD TYPE-2					

ADDITIONAL INFORMATION			
W.O. 44249A407-11			
STATUS OF DRAWING			
DISTRIBUTION OF PRINTS			
AME	-	1,	FBM - 4
IMM	-	3	
GTG (IMM)	-	1	

TYPE OF PRODUCT				1MJ763-2P				
OR				NAME OF CUSTOMER/PROJECT				
BHARAT HEAVY ELECTRICALS LTD. BHOPAL				DRN	VASU	-sd-	14.03.95	NO. OF VAR.
				CKD	J.C.G	-sd-	15.03.95	
				APPD	V.K.J./P.B	-sd-	10.06.95	

REV. DATE	03	18.05.13	ALTD. - K.N.P.-sd-	CHKD. - J.K.-sd-	APPD. - M.K.M.-sd-	REV. DATE	02	06.01.99	ALTD. - -sd-	CHKD. - -sd-	APPD. - -sd-	REV. DATE	01	24.09.98	ALTD. - -sd-	CHKD. - -sd-	APPD. - -sd-	DEPT. AME	UNTOL. DIMS. GR.	SCALE	WEIGHT (K.G.)	REF. TO ASSY. DRG.	ITEM NO.	NO. OF ITEMS																		
	STYLE NO. ADDED. DRAWING REDRAWN.										IN T.R.1 BP19383 WAS BP10787.										MATL. SPEC. WAS BP10787.										CODE 404		NTS		35		DRAWING NO. 34028042020		REV. 04			
																													SHEET NO. 1		NO. OF SHEETS 1											

DRG. NO. 34028042033

THE INFORMATION ON THIS DOCUMENT IS THE PROPERTY OF BHARAT HEAVY ELECTRICALS LIMITED. IT MUST NOT BE USED DIRECTLY OR INDIRECTLY IN ANY WAY DETRIMENTAL TO THE INTEREST OF THE COMPANY.

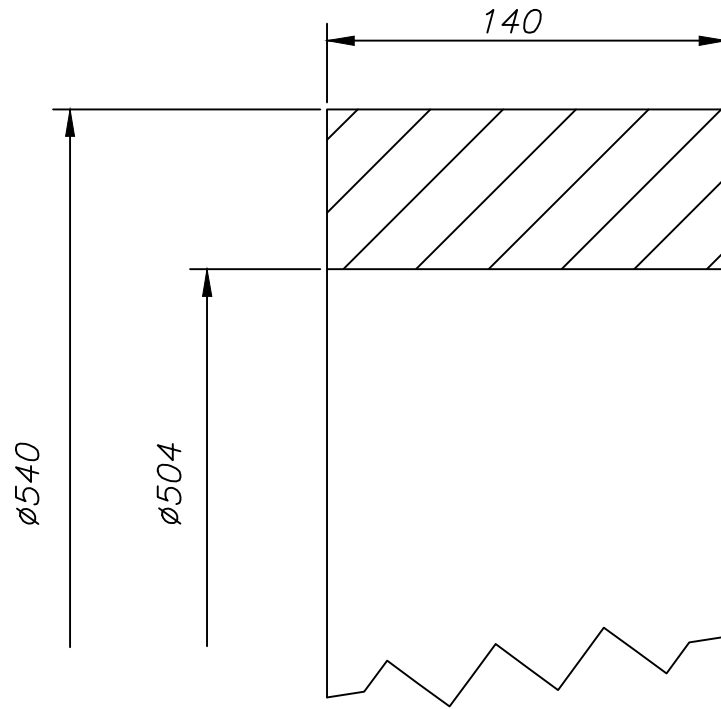

TECHNICAL REQUIREMENTS:-

1. RING TO BE FORGED MEETING PROPERTIES TO BP19383 & ULTRASONICALLY TESTED AS PER SPEC.
2. MACHINE ALL OVER. 12.5/
3. SHARP EDGES TO BE ROUND OFF.

STYLE NO. :- BP9504323936

01	SEE T.R.		001	RETAINING RING FORGED														32.6																		
59	64	65	75	78	79	25	27	29	58	59	60	77	29	31	34	45	55	56	57	58	65	72														
																			BP 19383		UNIT WT.															
VAR 01																			REMARKS		VAR. NO.		ITEM NO.		DESCRIPTION		DRAWING NO.		MATL. CODE		MATL. SPECN.		UNIT		QTY.	

ADDITIONAL INFORMATION W.O. 43150A401-11				TYPE OF PRODUCT OR NAME OF CUSTOMER/PROJECT 1LA780-2P																											
STATUS OF DRAWING				NAME OF CUSTOMER/PROJECT BHARAT HEAVY ELECTRICALS LTD. BHOPAL																											
DISTRIBUTION OF PRINTS AME - 1, FBM - 4 IMM - 3 GTG (IMM) - 1				DRN		V.K.H.		-sd-		16.03.04		NO. OF VAR.		CKD		J.C.G.		-sd-		16.03.04		APPD		P.B.		-sd-		16.03.04			
REV.		DATE		ALTD. - K.N.P.		REV.		DATE		ALTD. - K.N.P. -sd-		REV.		DATE		ALTD. - -sd-		DEPT. AME		UNTOL. DIMS. GR.		SCALE		WEIGHT (K.G.)		REF. TO ASSY. DRG.		ITEM NO.		NO. OF ITEMS	
03		09.08.17		CHKD. - J.K.		02		18.05.13		CHKD. - J.K. -sd-		01		24.09.09		CHKD. - -sd-		CODE 404		NTS		NTS									
WEIGHT 32.6 WAS 44, DRAWING REDRAWN.				STYLE NO. ADDED. DRAWING REDRAWN.				DIMN. 140 WAS 280. DRAWING REDRAWN.				TITLE RETAINING RING				DRAWING NO. 34028042033				REV. 03											
																SHEET NO. 1				NO. OF SHEETS 1											

FIRST ANGLE PROJECTION

(ALL DIMENSIONS ARE IN mm.)

REV.	DATE	ALTD. - DIPTI -sd-	REV.	DATE	ALTD. - K.N.P.	ADDITIONAL INFORMATION
		CHKD. - RAVI -sd-			CHKD. - J.K.	
		APPD. - A.K.M. -sd-			APPD. - M.K.M.	
08	09.03.23		07	18.05.13		W.O. 42032A421-11
DIA 545 WAS DIA 550.				STYLE NO. ADDED, DRAWING REDRAWN.		STATUS OF DRAWING
						DISTRIBUTION OF PRINTS
						AME - 1 , PLM - 3
						TCX(IMM) - 1 , IMM - 3

THE INFORMATION ON THIS DOCUMENT IS THE PROPERTY OF BHARAT HEAVY ELECTRICALS LIMITED IT MUST NOT BE USED DIRECTLY OR INDIRECTLY IN ANY WAY DETRIMENTAL TO THE INTEREST OF THE COMPANY.

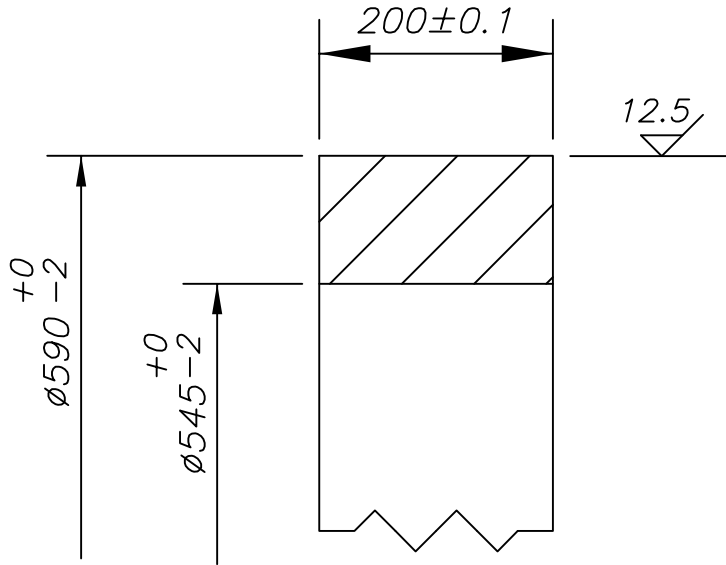

STYLE NO. :- BP9504323944.

TECHENICAL REQUIREMENTS :-

- MATERIAL SHALL MEET ALL THE REQUIRMENTS OF OUR SPEC. BP19383 & ULTRASONICALLY TESTED AS PER SPEC.
- 2NO. RINGS 90mm WIDE EACH, SHALL BE PRODUCED FROM THIS RING AT BHEL WORKS.

	001	RETAINING RING			63.0
			BP19383		
REMARKS	ITEM NO.	DESCRIPTION	MATL. CODE	A/C	UNIT WT.
			MATL. SPECN.		QTY.

SIGN & DATE

 BHARAT HEAVY ELECTRICALS LTD. BHOPAL	DRN	L.PATEL	-sd-	19.03.93	NO. OF ITEM
	CHD	P.K.S..K	-sd-	27.03.93	
	APPD	S.B.K.	-sd-	27.03.93	

INVENTORY NO.

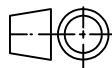
DEPT. AME	UNTOL DIMS GR.		SCALE NTS	WEIGHT(KG.)	REF. TO ASSY. DRG. -	ITEM NO. -	NO. OF ITEM
CODE 404							
TITLE					DRAWING NO.	REV.	
RETANING RING (ORDERING)					44028042035	08	
					SHEET NO. 01	NO. OF SHEETS 01	



**PLANT PURCHASING SPECIFICATION
BHOPAL**

BP 19381

Rev No. 03

PAGE 1 OF 6

**SUPERSEDES
BP 19381 Rev.02**

**NON-MAGNETIC CORROSION RESISTANCE
STEEL FORGINGS Gr. X 8 CrMn N18 18K**

1) GENERAL:

This specification governs the quality of forged and cold expanded, non-magnetic, corrosion resistant, steel forgings for Gr: X8CrMn N18 18K variety.

2) APPLICATION:

For manufacture of cap ring forgings of AC motors.

3) CONDITION OF DELIVERY:

Forged and cold expanded to achieve mechanical properties mentioned in Cl. 11.

Forgings shall be supplied in the rough machined and stress relieved condition, unless otherwise specified.

Our order shall specify the strength category (0.2% Rp Proof Stress) required.

4) COMPLIANCE WITH NATIONAL STANDARDS:

There is no Indian Standard covering this type of material.

5) DIMENSIONS AND TOLERANCES:

The dimensions of the forgings shall be as stated on the drawing or order. If the order/drawing calls for finished dimensions, the forgings are to be delivered with all side machining allowances of 3 to 4 mm to this finished dimension after rough machining. The surface roughness shall be maximum R2=6 µm for the non-destructive test, clause 12.

6) MANUFACTURE:

Material shall be manufactured from killed steel.

Revision :

Cl 7 updated

Issued by :

19.01.24
**STANDARDS AND MATERIALS GROUP
TECHNICAL SERVICES DEPARTMENT**

Rev.03

Date: 19.01.2024

Date of first Issue: Nov 1987



TSD 6207 A

**PLANT PURCHASING SPECIFICATION
BHOPAL**

BP 19381

Rev. No. 03

PAGE 2 OF 6

7) HEAT TREATMENT:

The material is to be forged and cold expanded within 300 Deg.C. A hot cold deformation is not permissible. No age-hardening is permitted. The forgings are to be stress-relieved, at least 5 hours at 350 deg.C \pm 20 deg.C after the cold expansion.

8) FREEDOM FROM DEFECTS:

The forgings shall be sound, clean and free from cracks, flakes, seams, segregation, harmful non-metallic inclusions other defects.

9) CHEMICAL COPOSITION:

The chemical composition of the steel shall be as follows:

Element	Percentage	
	Minimum	Maximum
Carbon	-	0.12
Silicon	-	0.80
Manganese	17.50	20.00
Phosphorus	-	0.05
Sulphur	-	0.015
Chromium	17.50	20.00
Nitrogen	0.40	-

10) TEST SAMPLES:

One tangential test samples shall be selected per heat treatment batch, per consignment for mechanical properties. Tangential samples are to be taken from the forged specimen from the center of the wall thickness after the last heat treatment.

11) MECHANICAL PROPERTIES:**11.1 Tensile:**

When tested in accordance with IS:1608/DIN 50145 & 50125 the test pieces shall show, the properties given in the table below:

11.2 Impact value:

Charpy-ISO-V-Notch when tested in accordance with IS: 1498/DIN 50115 the test pieces shall show the properties given in the table below, mean of three tests shall be taken.



TSD 6207 A

PLANT PURCHASING SPECIFICATION BHOPAL

BP 19381

Rev. No. 03

PAGE 3 OF 6

*0.2% Proof Stress N/mm ² Min	% Elongation 5.65√So GL, Min	Reduction in Area Percent Min	Charpy Impact Value –ISO-V- Notch “J” Min.
550	37	61	130
600	35	60	125
650	32	59	120
700	30	58	110
750	28	57	105
800	26	55	100
850	24	54	95
900	22	53	90
950	20	52	80
1000	18	51	75

*Note:

1. Strength category (0.2% Rp) shall be specified in the order.
2. The measured 0.2% proof stress is permissible to exceed the required minimum value by 150 N/mm² maximum.
3. The tensile Strength shall be mentioned for information in Test certificate.

12) NON DESTRUCTIVE EXAMINATION:

12.1 Ultrasonic Examination:

The ultrasonic testing shall be performed on 100% of the external surface with a standard test probe in radial direction and width 45 deg. Angular probe, twice in periphery direction and twice in axial direction. Test frequency shall be 1 or 2 MHz. The desired surface finish shall be less than or equal to 6 μm.

Note: With the calibrator attenuator, the back-wall or edge echo is adjusted to 100% screen height and then increase the gain by 12 dB. Any texture noise / grass echos appearing should not exceed 20% of screen height.

The ultrasonic testing shall be performed as per BHEL Corporate Standard AA 085 01 18 and the following shall be the unacceptable defects (category I of AA 085 01 18).

- a) Cracks, flakes, seams and laps.
- b) Defects giving indication larger than that from a 2 mm diameter equivalent flaw.



TSD 6207 A

PLANT PURCHASING SPECIFICATION BHOPAL

BP 19381

Rev. No. 03

PAGE 4 OF 6

- c) Groups of defects with maximum indication less than that from a 2 mm diameter equivalent flaw which cannot be separated at testing sensitivity if the back-echo is reduce to less than 70%.
- d) Defects giving indications of 1 and 2 mm diameter equivalent flaws separated by a distance less than four times the size of the larger of the adjacent flaws.

12.2 Liquid Dye Penetration Examination

Liquid dye penetrate test is to be carried out in 100% surface of the forgings to examine freedom from cracks as per DIN 54152 part I and the indications are to be recorded and marked on the forging.

13) INSPECTION AT SUPPLIER'S WORKS:

Whenever specified tests and inspection are to be conducted in the presence of BHEL's representative.

BHEL representative shall have free access at all times while the work on the contract is being performed to all parts of the manufactures works. The manufacturer shall offer BHEL's representative all reasonable facilities, without charge to satisfy the later that the material is being furnished in accordance with this specification.

The manufacturer shall prepare and provide necessary test specimen for testing to be carried out at his premises. If facilitate are not available at his work the manufacturer shall make necessary arrangements for carrying out the prescribed tests elsewhere. The manufacturer shall notify BHEL in advance about readiness of the material test the material at BHEL's works and the final acceptance of the material shall be based on these test results.

14) REWORK:

Repair or elimination of insignificant defects shall not be carried out without the prior permission of BHEL.

15) TEST CERTIFICATE:

Three copies of test certificates shall be supplied, unless otherwise stated on the order in the 'test certificate' proforma annexed to this specification (Annexure-I).

In addition, the supplier shall ensure to enclose one copy of the test certificate along with their dispatch documents to facilitate quick clearance of material.



TSD 6207 A

PLANT PURCHASING SPECIFICATION BHOPAL

BP 19381

Rev. No. 03

PAGE 5 OF 6

16) PACKING AND MARKING:

Forgings shall be suitably packed to prevent corrosion & damage during transit.

Machine surface shall be properly protected with anti-corrosive compounds.

Each package or forgings (when supplied separately) shall be legibly marked with paint with the following information:-

BP 19381: Non-magnetic Corrosion resistance steel forgings Gr:X8CrMnN18 18K

BHEL Order No. (on the inner surface)

Consignment or identification No.

Batch No.

Weight

Supplier's Name.

17) REJECTION AND REPLACEMENT:

If the forging does not comply with the requirements of this specification during receipt inspection at BHEL or if any defect is found during the course of preparation, machining, testing or erection such forging shall be rejected notwithstanding any previous certification of satisfactory testing and/or inspection.

The manufacturer shall undertake to replace the rejected forgings at his own cost and the rejected forgings shall be taken back by the supplier after fulfilling the commercial terms and conditions.



TSD 8207 A

PLANT PURCHASING SPECIFICATION BHOPAL

BP 19381

Rev. No. 0 3

PAGE 6 OF 6

Recommended Test Certificate Format For Forgings Annexure-1 Supplier's Name and Address

1. Customer. 2. TC No & Date: 3. PO No.: 4. Process of Melting Ingot: 6. Deoxidation Process: 6. Forging Method: 7. BHEL's Reference for Approval of Bloom 8. Discard: Top 5.: Bottom %	9. Reduction Ratio 10. Batch No.: 11. Heat/Melt No. 12. Spec.No. 13. Test Bar Size & Nos. 14. Supplier of the Ingot/Billet/V Bloom and IC reference.
--	---

15 F ORINGS COVERED BY RTIFICATE

S.No	Drawing No & Item No	Description	Quantity & Weight

16. CHEMICAL COMPOSITION (PERCENT)

Element	C	Sr	Mn	S	P								
As Per Spoon	Min.												
	Max.												
Actual Values													

17. HEAT TREATMENT

(To be accompanied by Recorder Chad, Whenever called for)

Condition	Heating Rate, °C/hr.	Temp. °C	Soaking Time, Hrs.	Cooling Rate, °C/hr	Cooling Medium

18. MECHANICAL PROPERTIES

	TS N/mm ²	Y.S 0.5/0.2% Proof N/mm ²	% Elongation s&54'S'O GI	%FLA. Min.	Hardness EIHN (Min.3 values)	Impact Value Jail%	Bend Test			
							Angle of bend	Dia of mandrel	Result	
As Per	Min.									
Spam	Max.									
Actual Values										

19. SURFACE FINISH (When called for in the order/drg) 1

20. DIMENSIONAL INSPECTION

21. NON-DESTRUCTIVE TESTS

Nature of Test	Acceptance level	Instrument used	Range	Results	Any other detail
Ultrasonic					
Radiographic					
Dye penetrant/ Magnetic Particle					

22. METALLOGRAPHIC EXAMINATION

(To be conducted if called for and photo micrographs to be attached along with a report)

Location of Sample	Etchant used	Magnification	Constituent observed	Relative.

23. OTHER TESTS IF ANY (MICROSCOPIC, SULPHUR PRINTS, E TC)

24. IDENTIFICATION OF FORGINGS AS PER PURCHASE SPEC.

We hereby certify that the items mentioned above have been tested and inspected in our presence and are found to be in accordance with drawings, specifications and purchase order.

SIGNATURE, NAME & SEAL OF THE
INSPECTING OFFICER
DATE.

SIGNATURE, NAME & SEAL OF THE
CHIEF OF QUALITY CONTROL
CHIEF METALLURGIST OF THE SUPPLIER
DATE:

INSTRUCTIONS

- a) Details of all heat treatment processes carried out should be furnished sequentially in 17.
- b) Test certificates are to be issued as per Purchase order and specification, in A4 size preferably in transparent paper.
- c) All the entries including signature should be in black colour ink.
- d) If testing is done by outside agencies, the original 'Ms shall be furnished.
- e) The actual IC may run into more than one A4 size paper, if needed, to facilitate filling up of details.



TSD 6206

PLANT PURCHASING SPECIFICATION BHOPAL

BP 19383

Rev No. 02

PAGE 1 OF 5

STAINLESS STEEL FORGINGS Gr. X 4 CrNiMnMo N 19138

SUPERSEDES
BP 19383 Rev.01

1 GENERAL :

This Specification governs the quality of stainless steel forgings of Gr: X4CrNiMnMo N 19138 variety.

2 APPLICATION :

For manufacture of retaining ring for 2 pole squirrel Cage Motors.

3 CONDITION OF DELIVERY :

Forged, and heat treated to achieve mechanical properties mentioned in Cl.11.

Forgings shall be supplied in the rough machined and Stress Relieved Condition, unless otherwise specified.

4 COMPLIANCE WITH NATIONAL STANDARDS :

There is no Indian Standard covering this type of material.

5 DIMENSIONAL AND TOLERANCE :

The dimensions of the forgings shall be as stated on the drawing or order. If the order / drawing calls for finished dimensions, the forgings are to be delivered with all side machining allowances of 3 to 4 mm to this finished dimensions after rough machining. The surface roughness shall be maximum $Ra=6 \mu m$ for the non-destructive, clause 12.

6 MANUFACTURE :

Material shall be manufacture by an electric process or any other approved process.

Revision :

Reviewed & No Tech. Change

Issued by :

STANDARDS AND MATERIALS GROUP
TECHNICAL SERVICES DEPARTMENT

Rev.02

Date: 25.01.2020

Date of first Issue : Feb 1986

COPYRIGHT AND CONFIDENTIAL
The information on this document is the property of Bharat Heavy Electricals Limited, Bhopal.
It must not be used directly or indirectly in any way detrimental to be interest of the company



TSD 6206

PLANT PURCHASING SPECIFICATION BHOPAL

BP 19383

Rev. No. 02

PAGE 2 OF 5

7. HEAT TREATMENT :

The material shall be heat treated to achieve the mechanical properties specified in clause 11.

8. FREEDOM FROM DEFECTS :

The forging shall be sound, clean and free from cracks, flakes, seams, segregation harmful non-metallic inclusion or other defects.

9. CHEMICAL COMPOSITION :

The chemical composition of the steel shall be follows :

Element	Percent	
	Minimum	Maximum
Carbon	-	0.15
Silicon	-	1.00
Manganese	7.00	10.00
Phosphorus	-	0.030
Sulphur	-	0.020
Chromium	17.50	20.00
Nitrogen	0.20	0.40
Molybdenum	2.50	3.50
Nickel	12.00	15.00

10. TEST SAMPLE :

One tangential test sample shall be selected per heat per heat treatment batch, per consignment for mechanical properties. Tangential samples are to be taken from the forged specimen from the center of the wall thickness after the last heat treatment.

11. MECHANICAL PROPERTIES :

11.1 Tensile :

When tested in accordance with IS:1608/DIN 50145 & 50125 the test pieces shall show, the properties given below :

Tensile Strength	-	700 – 900 N/mm ²
0.2% Proof Stress	-	410 N/mm ² Min.
Elongation on $5.65\sqrt{S_0}$ Gauge length	-	35 Percent Minimum

12. NON DESTRUCTIVE EXAMINATION :



PLANT PURCHASING SPECIFICATION BHOPAL

BP 19383

Rev. No. 02

PAGE 3 OF 5

13. Ultrasonic Examination :

The ultrasonic testing shall be performed on 100% of the external surface with a standard test probe in radial direction and width 45 deg. Angular probe, twice in periphery direction and twice in axial direction. Test frequency shall be 1 or 2 MHz. The desired surface finish shall be less than or equal to 6 μm .

Note : With the calibration attenuator, the back wall or edge echo is adjusted to 100% screen height and then increase the gain by 12 dB. Any texture noise / grass echoes appearing should not exceed 20% of screen height.

The ultrasonic testing shall be performed as per BHEL corporate standard AA 085 01 18 and the following shall be the unacceptable defects (category I of AA 085 01 18).

- a) Cracks, flakes, seams and laps.
- b) Defects giving indication larger than that from a 2 mm diameter equivalent flaw.
- c) Groups of defects with maximum indication less than that from a 2 mm diameter equivalent flaw with cannot be separated at testing sensitivity if the back – eco is reduced to less than 70%.
- d) Defects giving indications of 1 to 2 mm diameter equivalent flaws separated by distance less than four times the size of the larger of the adjacent flaws.

12.1 Liquid Dye Penetration Examination

Liquid dye penetration test is to be carried out in 100% surface of the forgings to examine freedom from cracks as per DIN 54152 Part I and the indications are to be recorded and marked on the forging.

13 INSPECTION AT SUPPLIER'S WORKS :

Whenever specified tests and inspection are to be conducted in the presence of BHEL's representative.

BHEL representative shall have free access at all times while the work on the contract is being performed to all parts of the manufacture's works. The manufacture shall offer BHEL's representative all responsible facilities, without charge, to satisfy the letter, that the material is being furnished in accordance with this specification.

The manufacturer shall prepare and provide necessary test specimen for testing to be carried out at his premises. If facilities are not available at his work manufacture shall make necessary arrangements for carrying out the prescribed tests elsewhere.



TSD 6206 A

PLANT PURCHASING SPECIFICATION BHOPAL

BP 19383

Rev. No. 02

PAGE 4 OF 5

The manufacture shall notify BHEL in advance about readiness of the material for inspection and testing. BHEL reserve the right to test the material at BHEL's work and the final acceptance of the material shall be based on these test results.

14. REWORK :

Repair or elimination of insignificant defects shall not be carried out without the prior permission of BHEL.

15. TEST CERTIFICATE :

Three copies of test certificates shall be supplied, unless otherwise stated on the order in the 'Test Certificate' proforma annexed to this specification, (Annexure – I).

In addition, the supplier shall ensure to enclose one copy of the test certificate along with their dispatch documents to facilitate quick clearance of material.

16. PACKING AND MARKING :

Forgings shall be suitably packed to prevent corrosion & damage during transit.

Machined surfaces shall be properly protected with anti-corrosive compounds.

Each package or forging (when supplied separately) shall be legibly marked with paint with the following information.

BP 19383: Stainless Steel Forging Gr : X4CrNiMnMo N 19138.

BHEL Order No.

Drawing No. (on the inner surface)

Consignment or Identification No.

Batch No.

Weight

Supplier's Name.

17. REJECTION AND REPLACEMENT :

If the forging does not comply with the requirements of this specification during receipt inspection at BHEL or if any defect is found during the course of preparation, machining, testing or erection such forging shall be rejected notwithstanding any previous certification of satisfactory testing and / or inspection.

The manufacture shall undertake to replace the rejected forgings at his own cost and the rejected forgings shall be taken back by the supplier after fulfilling the commercial terms and conditions.



TSD 6206 A

PLANT PURCHASING SPECIFICATION BHOPAL

BP 19383

Rev. No. 02

PAGE 5 OF 5

Recommended Test Certificate Format For Forgings Annexure-1

Supplier's Name and Address

1. Customer: 2. TC No. & Date: 3. PO No.: 4. Process of Melting Ingot: 5. Decarburisation Process: 6. Forging Method: 7. BHEL's Reference for Approval of Bloom: 8. Discard: Top _____ %; Bottom _____ %	9. Reduction Ratio } Ingot to Bloom } Bloom to Blank 10. Batch No.: 11. Heat/Melt No.: 12. Spec. No.: 13. Test Bar Size & Nos. 14. Supplier of the ingot/billet/ Bloom and TC reference.															
15. FORGINGS COVERED BY TEST CERTIFICATE																
S.No	Drawing No. & Item No	Description	Quantity & Weight													
16. CHEMICAL COMPOSITION (PERCENT)																
Element	C	Si	Mn	S	P											
As Per Specn	Min.															
	Max.															
Actual Values																
17. HEAT TREATMENT (To be accompanied by Recorder Chart, Whenever called for)																
Condition	Heating Rate, °C/hr.	Temp. °C	Soaking Time. Hrs.	Cooling Rate, °C/hr	Cooling Medium											
18. MECHANICAL PROPERTIES																
As Per Specn	Min.	Max.	Actual Values	T.S N/mm ²	Y.S 0.5/0.2% Proof N/mm ²	% Elongation 5.65√So GL	% R.A. Min.	Hardness BHN(Min. 3 values)	Impact Value Joules	Bend Test						
				Angle of bend	Dia of mandrel	Result										
19. SURFACE FINISH (When called for in the order/drg)																
20. DIMENSIONAL INSPECTION																
21. NON-DESTRUCTIVE TESTS																
Nature of Test	Acceptance level	Instrument used	Range	Results	Any other detail											
Ultrasonic																
Radiographic																
Dye penetrant/ Magnetic Particle																
22. METALLOGRAPHIC EXAMINATION (To be conducted if called for and photo micrographs to be attached along with a report)																
Location of Sample	Etchant used	Magnification	Constituent observed	Relative %												
Microstructure	Macroetch	Inclusion Rating														
23. OTHER TESTS IF ANY (MICROSCOPIC, SULPHUR PRINTS, ETC)																
24. IDENTIFICATION OF FORGINGS AS PER PURCHASE SPEC																
We hereby certify that the items mentioned above have been tested and inspected in our presence and are found to be in accordance with drawings, specifications and purchase order.																
SIGNATURE, NAME & SEAL OF THE INSPECTING OFFICER DATE										SIGNATURE, NAME & SEAL OF THE CHIEF OF QUALITY CONTROL/ CHIEF METALLURGIST OF THE SUPPLIER DATE:						
INSTRUCTIONS																
a) Details of all heat treatment processes carried out should be furnished sequentially in 17																
b) Test certificates are to be furnished as per Purchase order and specification, in A4 size preferably in transparent paper.																
c) All the entries including signature should be in block colour ink.																
d) If testing is done by outside agencies, the original TCs shall be furnished.																
e) The actual TC may run into more than one A4 size paper, if needed, to facilitate hang up of details.																